



# Los Feliz Ledger

Vol 4, No. 10

Serving the Greater Los Feliz, Silver Lake & Hollywood Hills Area | Distribution 34,500

May 2009

## Crime & Economy? The Jury's Out

By Jennifer Haning  
Ledger Contributing Writer

**LOS FELIZ**—Even though the Los Angeles Police Dept. reports a decrease in property and violent crimes citywide, unusual criminal activities in the area are increasingly being reported.

These sporadic crimes include various Internet and telephone scams, transactions involving counterfeit currency and even an attempted kidnapping last month near Thomas Starr King Middle School.

However, experts differ on whether the up tick in these crimes can be directly traced to the current economic climate and the county's current 11.3% unemployment rate.

"There are arguments on both sides regarding a direct connection between the two," said Los Angeles Police Dept. Senior Lead officer Lenning Davis of the Northeast Division. "I have heard law professors arguing on both sides about this without a clear answer."

According to police data, violent crime is down 7% from 2008 and 11.8% from 2007. Property crime is like-  
*see Crime Wave page 27*



**SUMMER'S ALMOST HERE**—McGoremic and Naomi Chin of Silver Lake swing high at Bellevue Park as their grandfather, Lin stands watch behind them.  
*Photo by Michelle Kunz*

## "Selected Not Elected" Proposal To Be Decided This Month

By Allison B. Cohen

**LOF FELIZ**—The Greater Griffith Park Neighborhood Council (GGPNC) will vote in May if it should change how its appointed members are selected or to reduce the number of its appointed seats altogether, a proposal issued by council member Tomas O'Grady.

The board took public comment on the matter at its April 21st meeting, but opted to not vote on the issues as the pub-

lic—President Phillip Gasteier said—had not been fully notified of the matter through the council's posted agenda.

O'Grady's proposal calls for a change in the council's bylaws, which had not been indicated in the council's agenda posted prior to the meeting.

The issue is time sensitive as nine board members are up for reappointment in August.

O'Grady's proposal has

two parts: the first recommends only elected members vote on appointments this August; the second seeks to reduce the number of appointed seats altogether to four for the 2010 public election.

According to O'Grady, his proposal has received 524 signatures and 26 letters in support from GGPNC stakeholders.

"I do think we will prevail," said O'Grady. "I think democracy will prevail."

O'Grady initiated what he calls the "Elected, Not Selected" campaign in late March after discovering the GGPNC is only one of handful of neighborhood councils in the

*see GGPNC page 4*

## Budget Axe Misses Library, So Far

By Kimberly Gomez, Ledger Contributing Writer

**LOS ANGELES**—As expected, Mayor Antonio Villaraigosa's Proposed 2009-10 budget

growing needs of residents and visitors during these challenging economic times."

"Despite the challenges of one of the most difficult budgets the city has ever faced, the mayor has demonstrated that he values and supports the important role that our libraries play," said John

Cooke of the Library Foundation of Los Angeles, a non-profit fund raising organization.

Even though hours have been thus far spared, the library is still facing the possibility it will need to trim \$6.3 million in salary costs—the equivalent of 115 library positions out of 1,136 citywide.

"We don't know if the re-

duction will be made through work furloughs, early retirements, layoffs or a combination," said library spokesperson Peter Persic. "If we had to eliminate 115 filled positions, it would be very difficult to maintain existing service hours."

Increased demand for libraries is typical during economic downturns. In the midst of what the mayor calls the city's worst financial crisis since the Great Depression, it is estimated the 10% rise in use for libraries, compared to last year, will continue.

Increasing numbers of patrons have been using libraries—nationwide—to read magazines and to check out DVDs, discretionary items they

*see Library page 7*



Amanda Law browses the stacks at the Los Feliz Library.  
*Photo by Michelle Kunz*

called for deep spending cuts citywide, but it came as a surprise to some that the Los Angeles Public Library budget was, thus far, spared.

Citing 17 million in both library visits and items circulated over the last year—Los Angeles' highest usage ever—the mayor's budget proposes to maintain existing hours at all of the library's 72 branches "to support the

## "BID" Protest Fails

by Rachel Heller  
Ledger Contributing Writer

**LOS FELIZ**—A move to disband the Los Feliz Village Business Improvement District (BID) failed last month, but has highlighted long-brewing dissatisfaction with the BID among some local merchants.

Over 50 local business owners signed protest forms calling on the city to shut the BID down before its annual renewal date April 14th.

Many said they have felt for years that the BID has not done enough for the community with the mandatory fees it collects from local merchants.

Los Angeles BIDs—of which there are 38—provide neighborhood beautification services such as trash bins and tree trimming, for example. The organizations are funded by mandatory assessments that businesses (or property owners, in some cases) pay yearly. In 2008, the BID estimated its assessments at \$81,300.

Concerns over Los Feliz's BID came to a head in February after several local merchants did not receive ballots for the board's annual election.

A contingent of these business owners then mounted a campaign to officially disband the group.

The group, calling itself "Get Rid of the BID," needed signatures of businesses representing 50 percent of the assessed fees the BID gathers each year. The 56 merchants

*see BID page 5*

## Netty Carr Honored for Community Involvement



State Senator Carol Liu, (21st District—bottom left, sitting) honored Atwater Village's Netty Carr (standing, second from left) as one of a select group of 2009 Women of the Year. Also honored were Marcia Amoroso, Rachel Chen, Georgina Holloway and Mercy Valezquez (pictured). Carr has been involved with the beautification of the Los Angeles River, is the co-founder of Friends of Atwater Village and was instrumental in saving the historic Van de Kamp's Bakery Building in Glassell Park from demolition. The site now is being considered for a satellite campus of Los Angeles City College.



[LETTER FROM THE PUBLISHER]

This month, we received so many requests for editorial submissions and letters we expanded our "Open Mike" section by a page. The section is one of my favorites. It's there for you, the community—a space for your point of view.

If you send us an editorial, we will more than likely print it. I can only remember turning down one piece in the five years the paper has existed. It was on UFOs and there was something going on more urgent that month than the speculation of life on other planets.

Over the years, we've

printed editorials about a variety of topics. Doing so does not mean we endorse their content. The one place in the paper where my voice can be heard is in the column you are reading now. Occasionally, I have used this space to express my opinion on such things as the BID, the lack of ballparks in Griffith Park and my joy of my son's education at the Thomas Starr King Magnet. But this is where my opinion starts and stops.

In this edition, we once again look at an issue raised first last month by Greater Griffith Park Neighborhood Council member Tomas O'Grady regarding how the GGPNC board is composed. I

am hopeful in this edition we have been fair in providing not only his but alternative points of view.

That is the role of a newspaper—community or otherwise—in a democracy.

**CORRECTIONS & AMPLIFICATIONS**

In our "Going the Distance," column (April 2009) by Senior Moments columnist Stephanie Vendig, we incorrectly referred to an organization as the National Stroke Assoc. The organization should have been identified as the American Stroke Assoc. which is affiliated with the American Heart Assoc. We regret this error.

Los Feliz Ledger

FOUNDED 2005

Delivered the last Thursday of each month to 34,500 homes and businesses in the Los Feliz, Silver Lake and Hollywood Hills communities.

**PUBLISHER/EDITOR**  
Allison B. Cohen

**ADVERTISING SALES**  
Olga Measures

**GRAPHIC DESIGN & LAYOUT**  
Tiffany Sims

**OFFICE ASSISTANT**  
Griffin O. Cohen

**LABELER, STAMPER AND TEARSHEET MANAGER**  
Charles "Chunny" Cohen

**Story ideas, submissions, advertising rates & inquiries contact:**

Allison Cohen

4459 Avocado St.

Los Angeles, CA 90027

Phone: 323-667-9897

Fax: 323-667-1816

acohen@loshelizedger.com

www.loshelizedger.com

Pick up the Los Feliz Ledger at dozens of locations:

**LOS FELIZ**

**Citibank**  
1965 Hillhurst Avenue  
**Dresden Restaurant**  
1760 N. Vermont Avenue

**House of Pies**  
1869 N. Vermont

**Louise's Trattoria**  
4500 Los Feliz Blvd.

**Los Feliz Public Library**  
1874 Hillhurst Avenue

**Los Feliz 3 Theaters**  
1822 N. Vermont

**Newsstand**  
Vermont and Melbourne

**Palermo**  
1858 N. Vermont

**Skylight Books**  
1818 N. Vermont

**SILVER LAKE**

**Casita del Campo**  
1920 Hyperion Ave

**Silver Lake Chamber of Commerce**  
1724 W. Silver Lake Drive

Mother's Day 2009

Compiled by Debru Petrov

Any event on this list will delight your mother. Don't forget her special day, Sunday, May 10th:

**Mother's Day Champagne Brunch Buffet & Afternoon Tea**

Breakfast, desserts, flavored teas and champagne. Moms can create their very own fresh floral bouquets for a nominal fee.

May 10th, 9:00 a.m. to 5:00 p.m.  
Millennium Biltmore Hotel

Smeraldi's Restaurant & Rendezvous Court  
506 Grand Ave.

Reservations Required:  
(213) 624-1011

www.millenniumhotels.com

**Mother's Day Luncheon**

A special day for homeless women and their children.

May 9th, Free Admission  
Los Angeles Mission

303 E. 5th St. (213) 629-1227  
www.losangelesmission.org

**Mother's Day All-Day Shopping Event**

Take your mom on a jewelry shopping spree. Scott Ryerson of Tepopa Trading Company from Tucson, Arizona will display his Native American jewelry collection from Navajo, Zuni, and Santo Domingo artists. Free Admission

May 9th, 10:00 a.m. to 4:00 p.m.

Autry National Center  
4700 Western Heritage Way

(323) 667-2000  
www.autrynationalcenter.org

**Mother & Daughter Book Club**

A book club for young girls ages 6 to 8 years old and their mommies.

May 4th, 4:00 p.m.  
Los Feliz Library

1874 Hillhurst Ave.  
(323) 913-4710

**Mother's Day Craft for Teens**

Create a special vase for mom's floral bouquet.

May 7th, 4:00 p.m.

Cahuenga Branch Library  
4591 Santa Monica Blvd.

(323) 664-6418

**Mother's Day Blues & Jazz Extravaganza**

Enjoy great music with performances by jazz legend, Barbara Morrison.

Other artists include, Lady Muffy Charles, J. Boykin, Joe Kincaid and The Soul Brothers. Bring your own picnic, drinks and lawn chairs.

May 10th, 3:00 p.m. to 8:00 p.m.  
(310) 670-6937

Tickets & Information:

www.jazznla.com/Mothers\_Day\_2009.html

**"Passionately Pink" Chocolate Afternoon Tea**

A portion of the proceeds will be donated to the Susan G. Komen for the Cure Foundation in support of breast cancer research.

May 10th, 12:00 p.m. to 4:00 p.m.  
Lobby Lounge

Langham, Huntington Hotel & Spa,  
1401 S. Oak Knoll Ave.

Pasadena, CA 91106

(626) 525-6434

www.pasadena.langhamhotel.com

**Mother's Day Weekend Festival**

Food, great musical groups, arts & crafts, carnival rides, free health screenings for mom, including free gifts.

May 9th, 10th, 12:15 p.m. to 10:00 p.m.

Free Admission

Olvera Street  
845 N. Alameda St.

(213) 628-1274 or (818) 734-2744

www.yelp.com/events/los-angeles-mothers-day-festival

**International Geranium Society Presents:**

**Mother's Day Geranium Show**

May 9th, 10th, 9:00 a.m. to 4:00 p.m.

Free with paid admission  
Los Angeles County Arboretum & Botanical Gardens

301 N. Baldwin Ave.  
Arcadia, CA

(626) 821-3222

www.arboretum.org

**Mother's Day Concert**

Angels In Venice, May 9th, 1:00 p.m.

Free with admission

Under the Oaks Stage

Descanso Gardens

1418 Descanso Drive

La Canada Flintridge, CA 91011

(818) 949-4290

www.descansogardens.org

**Mother's Day Weekend Outdoor Brunch Buffet**

Enjoy an outdoor patio brunch served with a variety of food selections.

May 9th, 10th 9:00 a.m. to 1:30 p.m.

Rose Garden Pavillion

Descanso Gardens

1418 Descanso Drive

La Canada Flintridge, CA 91011

Reservations required:

(818) 949-4290

www.descansogardens.org

**Silver Lake Family Dentistry**

General • Cosmetic • Implants  
Quality Oriented Private Practice

**DENTAL OFFICE OF Gary Manukyan, DDS**  
USC Graduate

1828 Hyperion Avenue,  
Los Angeles, CA 90027  
**323-522-6811**

**New Patient Special**  
Free Exam & Cleaning

**A Silverlake Legend Since 1962**  
Superb Mexican Food

**Casita del Campo**

323.662.4255  
1920 Hyperion Ave.  
Silverlake, CA  
www.casitadelcampo.com

**Kids Menu**  
Happy Hour  
3pm-7pm  
Everyday

\$2.00 off Cocktails  
\$1.00 off Beer & Wine  
\$2.00 off Appetizers

• Outdoor Patios • Cocktails • Banquet Room  
Open Daily From 11a.m.

# HAPPY MOTHERS DAY THE LOS FELIZ MEDSPA

**Get a FREE**  
rejuvenating facial  
for Mom with any  
purchase of \$150

**Photofacials \$250**  
(regular price \$400)

(not valid with any other offer, some restrictions apply).  
Expires May 31, 2009

- Fraxel
- Botox / Radiesse / Juvederm
- Laser Hair Removal
- Laser Vein Removal
- Photo Facials
- Medical Microdermabrasion
- Medical Grade Chemical Peels
- Cellulite Treatment
- Body and Facial Contouring
- Non Surgical liporeduction

All laser & injectible procedures are performed by experienced board certified physicians.

2107 North Hillhurst Ave. Los Angeles, CA 90027 (323)664-0186

www.losfelizmedspa.com **GIFT CERTIFICATES AVAILABLE**



**50% off**  
laser hair removal packages  
**\$99 Medical**  
Microdermabrasion

(not valid with any other offer, some restrictions apply). Expires May 31, 2009

## [ROVING REPORTER] GGPNC: Appointed vs. Elected Board Members



Compiled by  
**Jennifer  
Haning, Ledger  
Contributing  
Reporter**

The Greater Griffith Park Neighborhood Council consists of 19 board members; 10 seats are elected and the other nine are "appointed" by the other 10 board members. What are your thoughts on this type of selection process?



"I definitely think board members should be elected by people that live and do business in the neighborhood.

When appointed board members use their votes to elect other appointees or to re-elect themselves, things tend to get a little hairy."

- **Christian Ducale,**  
Owner-Cherry Pick Vintage, Franklin Avenue, Los Feliz



"What's the point of having a neighborhood council if the residents and business professionals can't fully control its

configuration? We should be able to elect representatives for each board position as we see fit. The GGPNC should be organized by members of our collective community in order to hold true to the mission "by the people, for the people". Otherwise, the concept of democracy loses face value."

- **Jarrod Haynes, Resident,**  
Glenfeliz Blvd, Atwater Village



"I think it is beneficial to have some appointed members on the neighborhood council. It's a good way to establish structure within the group and can be effective in maintaining its functional stability."

- **Keila Barnes, Resident,**  
Waverly Drive, Silver Lake



"The members may as well be appointed because there is a lack of public knowledge about the neighborhood council in general... It boils down to lack of communication - how little they actually communicate with us."

- **Nick Gallo, Owner-Blue Rooster Art Supplies,**  
Vermont Avenue, Los Feliz

### [ POLICE & FIRE BLOTTER MAY 2009 ]

Compiled by Jennifer Haning

#### LAPD: Northeast Area

**Homicide: 3**  
**Rape: 1**  
**Aggravated Assault: 58**  
**Robbery: 36**  
**Burglary: 42**  
**Burglary Theft from Vehicle: 117**  
**Grand Theft Auto: 81**  
**Personal/Other Theft: 62**

**Fatal Traffic Accident:** March 26th, morning, 1600 block of N. Vermont Avenue. Victim was sleeping in the rear driveway of a local business when a private ambulance struck him. Ambulance driver and passenger fled scene. The victim was pronounced dead at the scene of the accident.

**Homicide:** March 31st, 9:12 p.m., Atwater Village. The victim of a gang-related homicide, a 19-year old male, was killed in front of his home. Homicide investigators are still searching for witnesses to this crime.

#### LAFD: Northeast Area

**Structure Fire:** FS20-March 18th, 5:36 p.m. at 2130 N. Echo Park Avenue. Reports of fire and smoke and evidence of pack rat conditions. 37 Firefighters needed to knockdown fire in 39 minutes. No injuries reported.

**Physical Rescue:** FS41-March 31st, 5:18 p.m. at 1430 N. Sunset Plaza Drive. Traffic accident with vehicle over embankment, landing on street below. Female, 70s, extricated from vehicle. Patient was unresponsive and transported to an area hospital in grave condition.

**Jumper:** FS2-March 31st, 5:42 p.m. at Southbound 5 Freeway and Eastbound Pomona Freeway. Confirmed reports of a jumper from the Freeway overpass. Sigalert was issued for all Northbound lanes and lanes 1 thru 4 of Southbound traffic. Jumper, 17, was taken into police custody.

### [EARTH DAY 2009]

## Eco-Home Honored

**LOS FELIZ**—The City of Los Angeles honored Eco-Home Network, a Los Feliz based environmental organization celebrating its 20th anniversary last month.

Eco-Home, located at 4344 Russell Ave., is an on-going living research center that demonstrates ecological living in an urban environment. The home is a restored and retrofitted California style bungalow, circa 1911, that illustrates how wise property improvements can make a home warm, friendly yet environmentally sound and healthy.

To date, over 17,000 people have taken an Eco-Home tour, with another 500 expected this year.

Information: [ecohome@pacbell.net](mailto:ecohome@pacbell.net)

## CERT Training Offered

The Los Angeles Fire Dept.'s Community Emergency Response Team (CERT) is offering emergency preparedness training starting May 5th for seven weeks at the Russian Church Meeting Hall, 650 Micheltorena St. Classes run from 7 p.m. to 9:30 p.m.

To register contact Joanna Paden: (818) 216-0797.

## Graphic Design Classes Offered

Low cost computer graphic design classes, like Flash Animation and Web Design, are being offered for adults at the Metro Skills Center, 2801 W. 6th St., Monday through Thursday mornings from 10:45 a.m. to 1:15 p.m. and on evenings from 6 p.m. to 8:30 p.m. Call (213) 386-7269 for information.

[PEOPLE IN MY NEIGHBORHOOD]  
**All In The Family**

By Chris H. Sieroty, Ledger Guest Writer

**LOS FELIZ**—After Mark Cianciulli moved back last year to Los Angeles after attending college in San Diego, he was planning on getting his CPA license and helping his 88-year-old grandfather, Hugo Cianciulli, manage his

apartments on the second floor, had seen better days. Even last year a number of the retail spaces were empty. What remain were a traffic school, a photographer, a shoe store and Vincent Realty, where Hugo and his

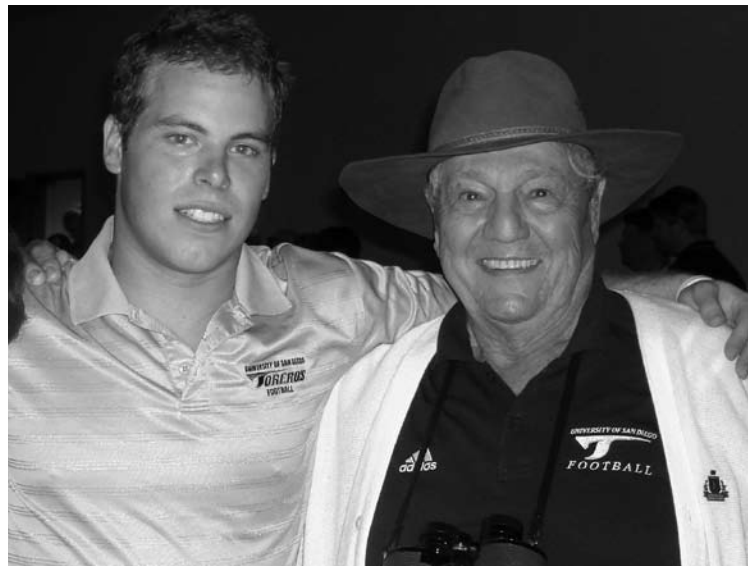

FAMILY BUSINESS: Mark Cianciulli with his grandfather Hugo.

real estate assets, including a building on Hollywood Boulevard near Vermont Avenue that Hugo owned with his brother Vincent.

But after Vincent's death, Cianciulli's plans changed. Seeing that a retail opportunity existed for the decaying 40-year-old building, Cianciulli with another partner, bought Vincent's share in the building.

"We bought the building as an investment and to keep it in the family," he said, "I also loved the neighborhood and thought we could attract a mix of really cool stores to an area that was already changing with the arrival of Confederacy and American Apparel."

The building, which offers some 6,000 square feet of retail space and 13 studio

brother shared an office for more than a decade.

But with Cianciulli now involved, the building's retail landscape was about to change.

"In the beginning I was told that [jewelry and imports store] Maya had been interested in leasing space in our building," said Cianciulli. "Once I spoke with them, I knew there was enough demand to change the building's retail space. Once Maya signed the lease, the others just followed."

Today, the 4600 block of Hollywood Boulevard has new shops such as Happy, a gift shop; and Solutions, a clothing store featuring made to fit denim jeans; Maya, and Vacation Vinyl, a record store which recently opened.

Cianciulli has also reno-

vated one of the second story studio apartments to use as an office for himself and his grandfather leaving the old storefront that housed Vincent Realty available for a shop or even a restaurant.

He is also lobbying the Los Feliz Village Business Improvement District, an association that promotes business growth in the area, to designate the stretch of Hollywood Boulevard as an arts and design district.

Cianciulli said doing so would separate their revitalized stretch of Hollywood Boulevard from the other stores located along Vermont Avenue in Los Feliz's main business district.

"It would be our little piece of Los Feliz, as unique as the store that have located to the area," he said.

*GGPNC from page 1*

city that has appointed seats.

Also, according to O'Grady, the GGPNC has the highest percentage of appointed seats of the 41 councils he has queried. There are a total of 89 councils in the city of Los Angeles.

About a dozen speakers from the audience commented on the issue including Susan Wood who simply said so many appointed members on a city funded board was "Un-American."

Others however, said there was no evidence of cronyism on the board, an issue raised in an editorial published by O'Grady in the April edition of the Los Feliz Ledger.

"Let's look at how appointed members have worked in this group," said Richard

Spicer. "There is no evidence of cronyism."

In fact, according to GGPNC president Gasteier, only three appointed members of the board have been reappointed over the years and that the appointed group has provided more ethnic and gender diversity than elected members.

"This is not a club," he said. "If you look at the names [of appointed members in the past] you will see Spanish surnames and Armenian surnames came from appointments." Women, he said, were also more likely to be appointed.

Ricardo Gomez, of Franklin Hills, who helped form the GGPNC in 2002, said the system was created to ensure a qualified and diverse set of volunteers were on the board from the start.

*see GGPNC page 27*

**BID from page 1**

who signed protest forms only represented 18 percent of the total district's assessed value.

"The BID board meets and talks among themselves, but they seldom get out into the community and ask businesses, 'What do you need?'" said Barbara Ferris, who runs a local non-profit and spearheaded the protest campaign. "There's a disconnect between the board and the people who pay the money. This BID is not working for us."

Some merchants complained the BID has not used funds efficiently for tree trimming or for outreach to the community about its needs like a lack of parking in the Village, for example.

"I really don't know where the money goes," said Zorab Mahdessian, owner of Jasmine's Garden flower shop on Hillhurst Avenue, who pays \$250 per year to the BID. The organization's beautification efforts are shoddy, he said, and the BID newsletter doesn't include relevant information for local merchants.

Rob Poston, owner of Avatar Computer Consulting, was one of several merchants who said he did not receive a ballot for the BID's February election. The idea of "taxation without representation," he said, pushed him to go into the community canvassing for protest signatures.

"I don't really see any benefit for the amount of money that they take out," he said.

Members of the business community had valid complaints about the election, said Ermanno Neiviller, owner of Il Capriccio restaurant and the BID's current president.

According to Neiviller, the BID sent out its election

ballots late this year and had them hand-delivered instead of sent by mail. If some businesses did not receive their ballots by mistake, he said, "I take full responsibility for that."

But while local merchants have the right to protest the BID, many don't realize the value of the services it provides, he said.

"We do lots of things behind the scenes that they never see," Neiviller said, including having on-going communicating with the Los Angeles Police Dept. "People don't see what we do, so they assume we don't do anything. That's not true."

BID secretary and past president Dora Herrera, owner of Yuca's on Hillhurst and Hollywood Boulevard said the BID performs services that otherwise would not be done, such as installing new trash cans in the neighborhood.

"The city doesn't have any money to do these services," she said. "We take up the slack."

Even though the campaign failed, Ferris said the protest has given a voice to dissatisfied business owners.

Ultimately, she said, the protest group prefers the area establish a membership based chamber of commerce.

"The question is, do we need to be paying this kind of money each year? We could make this [new representative group] what we want it to be, and not have it dictated to us," said Ferris.

For now, Ferris said her group is asking the BID to overhaul its bylaws and practice meeting standards set forth by the Brown Act. The group is also seeking the BID better assess the business community's needs, provide more

transparency on the BID's budgeting process and restructure assessment fees.

Ferris said the collection of 56 protest forms opposing the BID was an "incredible accomplishment."

"We're not going to go away," she said. "We're going to keep pressure on the BID board to clean up its act. There are a lot of changes that must be made."

**AYSO Registration for Fall 2009 is here!**

**May 16th, 10 a.m. to 1 p.m.**  
**Riverside Drive Soccer Field**

(located at Riverside Drive and Los Feliz Boulevard)

**Registration: \$100 for U8, U10 & U12, \$75 for U6**  
(price includes uniform cost)  
Scholarships Available

Season runs: Sept. 12th thru December 12th  
For additional information visit  
the AYSO website: [www.soccer.org](http://www.soccer.org)

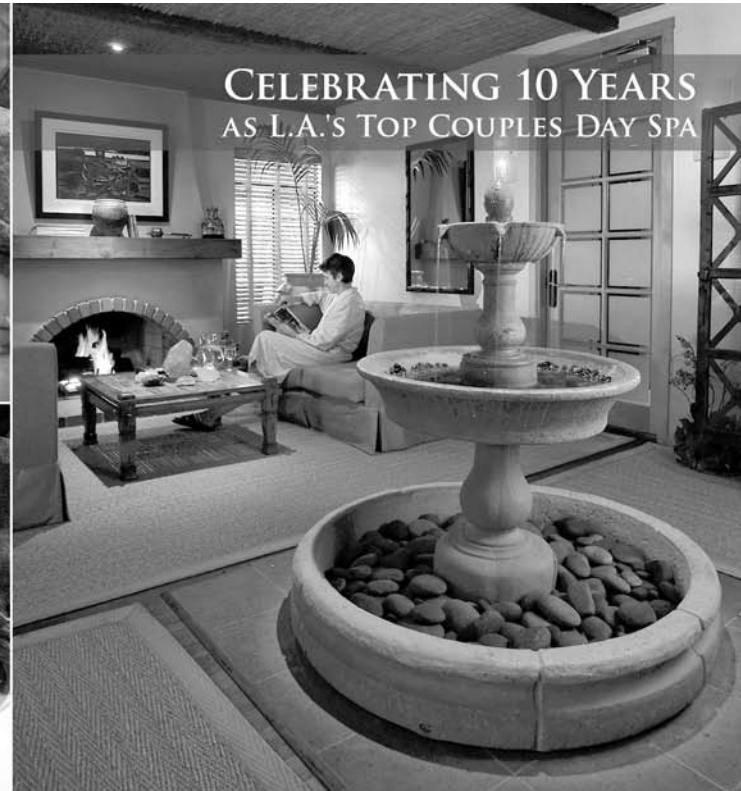

**CELEBRATING 10 YEARS**  
**AS L.A.'S TOP COUPLES DAY SPA**

**LE PETITE**  
**RETREAT**  
day spa

331 N. Larchmont Blvd., Los Angeles, CA 90004  
323.466.1028 | [LPRdayspa.com](http://LPRdayspa.com)

- Massage
- Facials
- Body Scrubs
- Lash Extensions
- Gift Certificates

**Show Your Gratitude On Mother's Day**

Spa with Mom for a lasting memory, or treat your special Mom to her own personal day with one of our famous spa packages. Thank the Mom who's made a difference in your life!

For VIP Specials Text "day spa" to "69302"

**Brownie Heaven**  
**in Atwater Village**



3169 Glendale Blvd.  
Atwater Village  
323.668.9338  
[www.sweetsforthesoul.com](http://www.sweetsforthesoul.com)

**Lark**  
**Silver Lake**  
**Cake Shop**

3337 W. Sunset Blvd.  
323.667.2968  
[larkcakeshop.com](http://larkcakeshop.com)

**Beautiful**  
**Delicious**  
**Delivered**

Pies • Cakes • Tarts • Cookies



- Drink**  
Available
- Tea
  - Coffee
  - Espresso
  - Espresso
  - Cappuccino
  - Latte
  - Café au Lait
  - Hot Chocci
  - French Press
  - Dry Soda

# Ecole du soleil



**lila summer school 2009**  
**june 22nd - july 31st 2009**  
**Pre-k to 5th grade**  
**Los Feliz campus**

## 8 reasons to choose us!

1. Our campus provides a safe and nurturing environment
2. No enrollment fees!
3. The basic tuition for one week is \$230. It costs less than almost any babysitter per day!  
Sign up two children and you get 10% off the second child's tuition cost!
4. Part Time: \$150 /week (3 days a week)
5. Daily registration: \$60
6. Day care service from 8:00 am to 9:00 am and 3:30 to 5:30 pm for FREE
7. You get 1 FREE t-shirt for the summer for your child when you enroll
8. ONE WEEK FREE If you take our special 6 week package. You will pay only \$1150

Visit us online: [www.lilaschool.com/camp](http://www.lilaschool.com/camp)

L'ECOLE DU SOLEIL - LYCEE INTERNATIONAL DE LOS ANGELES

4155 RUSSELL AVENUE, LOS ANGELES, 90027 CA

E-mail: [lyesse.tsamen@lilaschool.com](mailto:lyesse.tsamen@lilaschool.com) Tel: 1 323 665 4526 Fax: 1 323 665 2607

[ECHO PARK CORRESPONDENT]

**Filling A Gap—Arts Corps LA**

By Hayley Fox  
Ledger Contributing Writer



The educational and therapeutic benefits of art used to be readily recognized and even more than that; government funded. After the eradication of designated school periods for the arts, it is forced to become an outlet only for those who seek it, and this is often stipulated by familial economic situations.

The Arts Corps LA, now ACLA, is a non-profit organization that for 17 years has worked to incorporate science, nature, and arts into the development of those children who are without access to such luxuries. The Echo Park center is a small building overflowing with character and color, complete with brightly painted

murals and flowers.

The Arts Corps provides a safe place for neighborhood children to go after school and, in the upcoming summer months, all day. Using tutoring as a mere baseboard for the programs this center provides, the organization foregrounds the importance of an “outdoor classroom,” through expansive garden space, a makeshift stage for dance lessons, a skate park, a music room, and art supplies that range from the accessible to requiring a little ingenuity.

While the children tend to be between the ages of seven and 10, the doors are open to everyone in need of a haven or creative outlet. Encouraging volunteers to bring their own interests and talents to the program,

Arts Corps takes the sterility out of what is often considered “volunteering.” Interacting with the surrounding community, ACLA and its children do everything from paint murals on local liquor stores, to teaching neighborhood moms how to cook healthier, more nutritious meals for their families. Their mission is genuine and goals admirable, but with the constant need of additional hands, the ACLA is a place where donations of time and attention are just as valuable as money. [www.myspace.com/arts\\_corps\\_la](http://www.myspace.com/arts_corps_la)

*Library from page 1*

used to pay for. Additionally, as unemployment numbers grow in Los Angeles and throughout the state and nation, more job seekers are using libraries as make-shift offices.

Some branches offer assistance in resume writing. At the Atwater branch, so many are accessing employment websites on the library’s public computers, library staff installed an icon shortcut on computer desktops so job postings are now just a click away.

To bridge the gap of less

funds and more demand, library staffers say, they will lean more on organizations such as the Library Foundation of Los Angeles. That organization will host a fundraiser May 27th honoring Tom Brokaw.

“Even during these tough times, we are making it a priority to protect services to the extent possible,” said Los Angeles City Council President Eric Garcetti. A new branch in Silver Lake, he said, is expected to open this year regardless of budget issues.

[EARTH DAY 2009]

**Chamber Urges No More Plastic with “Earth Day Ball”**

**SUNSET JUNCTION**—In an effort to help eliminate the use of plastic bags, the Silver Lake Chamber of Commerce’s “Green Committee” collected over 6,000 plastic bags on Earth Day, April 22nd and made a giant “Earth Day Ball” with them.

Organizers said Silver Lake stores typically dole out about 6,000 plastic bags a month.

Students from Michelorena Street School gathered with chamber members and friends at the Sunset Junction Triangle Square to create the massive plastic ball and to urge passersby to quit using plastic.

The Green Committee has asked all local Silver Lake businesses to commit to no longer using plastic bags from Earth Day 2009 onwards and to encourage customers to bring their own reusable shopping bags.

For a list of those businesses that have made this pledge, visit the *Los Feliz Ledger* website at [losfelizledger.com](http://losfelizledger.com)

The plastic ball is now making the rounds at local schools to be used as an educational tool promoting the reduction of waste.



Dr. Cheryl Revkin, dressed in plastic bags, holds a sign demonstrating how many plastic bags one person uses in just a year. Photo credit: Allison B. Cohen

For more information about using the Earth Day Ball as an educational tool, please contact Cheryl Revkin at [Cheryl@cherylrevkin.com](mailto:Cheryl@cherylrevkin.com) or at (323) 665-1281.

*efua alvario*  
DENTISTRY

You have to go anyway so why not make the most of it?

**\$100 off on teeth whitening**

cappuccino • candles • ipods • blankets • and now movies!

Most insurance plans accepted.

323.644.2676 • 1655 Hillhurst Avenue, Suite 103

During May 10% of your receipt will be donated to Friends of Ivanhoe & you will receive a 10% discount with this ad.

**SILVERLAKE OPTOMETRY**  
Dr. Michel N. Kahwaji

- Comprehensive Eye Exams
- Treatment of Eye Disease
- Vintage & Designer Eyewear
- Bamboo Frames
- Contact Lenses
- Professional & Courteous Service
- Free Lasik Consultation

We accept VSP, Medi-Cal, Medicare & most other insurance

D&G VOQUE PRADA Maui Jim  
GUESS TOMMY HILFIGER

**(323) 664-1996**  
2771 Rowena Ave. (corner of Glendale Blvd.)  
Los Angeles, CA 90039  
[www.silverlakeoptometry.com](http://www.silverlakeoptometry.com)

**ALLSTON YACHT CLUB**  
1320 Echo Park Ave LA CA 90026

**FULL BAR**  
**SMALL PLATES DINING**  
**GOOD WINE BY THE GLASS**  
**213.481.0454**  
[allstonyachtclub.com](http://allstonyachtclub.com)

**PILATES Introductory Special!**  
Four Private Sessions for \$200\*

We offer smaller packages at competitive prices so that you can try Pilates to see if it's right for you.

Take advantage of sharing the cost of private sessions with other clients. We offer small & large group sessions on the reformer. No need to bring a partner, we'll match you up with someone.

We have experienced trainers certified in both the New York Method & West Coast Style Pilates.

**Mind Body FITNESS PILATES STUDIO**  
1947 1/2 Hillhurst Ave., Los Angeles, CA 90027  
We are 1 block North of Franklin Avenue in the heart of the Los Feliz Village  
Phone: (323) 661-2711 | [www.mind-bodyfitness.net](http://www.mind-bodyfitness.net)  
\*New clients for a limited time only

**We are open 7 days a week. Providing PILATES TRAINING in the Silver Lake/Los Feliz area for over 12 years!**

**[FRANKLIN AVENUE]  
Franklinpalooza  
is May 1st**  
by Sean Wilson,  
1st grade

My mom wants me to write something about Franklinpalooza-2009 the spring fundraiser at Franklin Avenue Elementary but I am finishing Harry Potter #5 so this is a joint effort. My Grandpa helped mom write stuff. A million years ago. Back then communities didn't have to fundraise for public schools. Back then there were no budget cuts.

What is Franklinpalooza? Friday, May 1st 5:30-9pm. Kids dancing in their own disco tent - Little kids supervised in The Clubhouse - Silent auction - Restaurants donating yummy food and families bringing home-cooked specialties - May Pole celebrating spring - Wee Soles hosting a gently used, fabulously priced shoe booth - "B.Y.O.C." Bring your own cup for water.

*\$10 adults, \$5 kids, free for under 5. Benefiting Friends of Franklin - non profit supporting Franklin Elementary. www.Franklinpalooza.com*

**[MICHELTORENA]  
Budget Cuts**  
by Crystal Ponce,  
4th Grader

I am outraged about budget cuts that will affect LAUSD schools. This is not right; education should come first!



If the budget cuts go through, my teacher Ms. Lopez may lose her job, like so many other LAUSD teachers. Also classrooms, overcrowded from raising class sizes, will be filled with so many children that the teachers will not be able to teach them all. Student's grades will fall. They will be cheated out of their education. Children will lose all hope; they will feel that their education is not valued by the government, and this makes me furious.

We should think about the next generation of leaders. I was taught by my family that education is the most important part of a person's life. In each school there is a doctor, lawyer, governor, teacher, and maybe a future president. We are in America; help us to protect, not destroy, the leaders of tomorrow.

**KING MIDDLE SCHOOL]  
Students Tour Europe**  
By Beja Wolf, 6th grade

In February, King students traveled throughout Europe on a 17-day tour, including Germany (Frankfurt, Heidelberg, Munich), Austria (Innsbruck), Switzerland (Lucerne), Italy (Venice, Florence, Rome), France (Paris, Colmar), and the United Kingdom (London).

In Venice, it flooded, and we were pick pocketed! In Rome, we saw majestic historical sights. Germany gave us opportunities to appreciate its quaint houses and in France we once again marveled at famous landmarks, visited Sacre Coeur for a night, and enjoyed the City of Lights on a Seine cruise on Valentines Day.

In Florence we appreciated beautiful Statue of David at the Academia Museum, ate wonderful gelatos, and tried on some great leather. In Switzerland, we

ended up in a snowstorm and had lots of snowball fights. We also learned how to convert Euros into a whole other currency. And finally, in London, where we ate fish & chips, went on the London Eye, and got to experience a new kind of London life by visiting Camden Town, home to punk rock.

This trip showed me places I'd love to go back to, taught me a lot, and gave me some photography experience. For kids our age, I think it is extremely important to get a taste of a foreign country, to teach us life experiences and how it is to be an outsider. To try new things, new places, work with new people, to live independently. My friends and I still laugh about incidences on the trip! It is something that will stick with us forever.

**Juvie**  
Clothes and Gifts for Older Kids

*New Looks For Spring  
Arriving Now!*

Finally, a store for your  
**OLDER  
BOYS & GIRLS...**

**Modern fashion**  
with a sense of **STYLE**  
and *whimsy* in sizes 7-14,  
plus unique gifts and gear  
that kids adore.

2395-C Glendale Blvd.  
Los Angeles, 90039

323.667.0344  
www.juvieshop.com

# Pilgrim School

Preschool through Grade 12

## Need room to grow?

When it comes to education, one size does not fit all. Every child has unique gifts and talents. At Pilgrim, we believe students will be most successful not by fitting in, but by standing out. By maintaining small classes (average of 15 students), Pilgrim provides an academic environment that gives students the individual attention they need to thrive.

Call for a tour and learn about our one to one laptop program, AP classes, sports, modern languages, art and music programs. 100% of Pilgrim graduates matriculate to the finest colleges and universities.

**Pilgrim School. We grow students.**

**Select spots available for the '09-'10 school year.**

**PILGRIM SCHOOL**  
College Preparatory Day School since 1958  
Pilgrim School • 540 S. Commonwealth Avenue • Los Angeles, CA 90020 • (213) 385-7351 • www.pilgrim-school.org

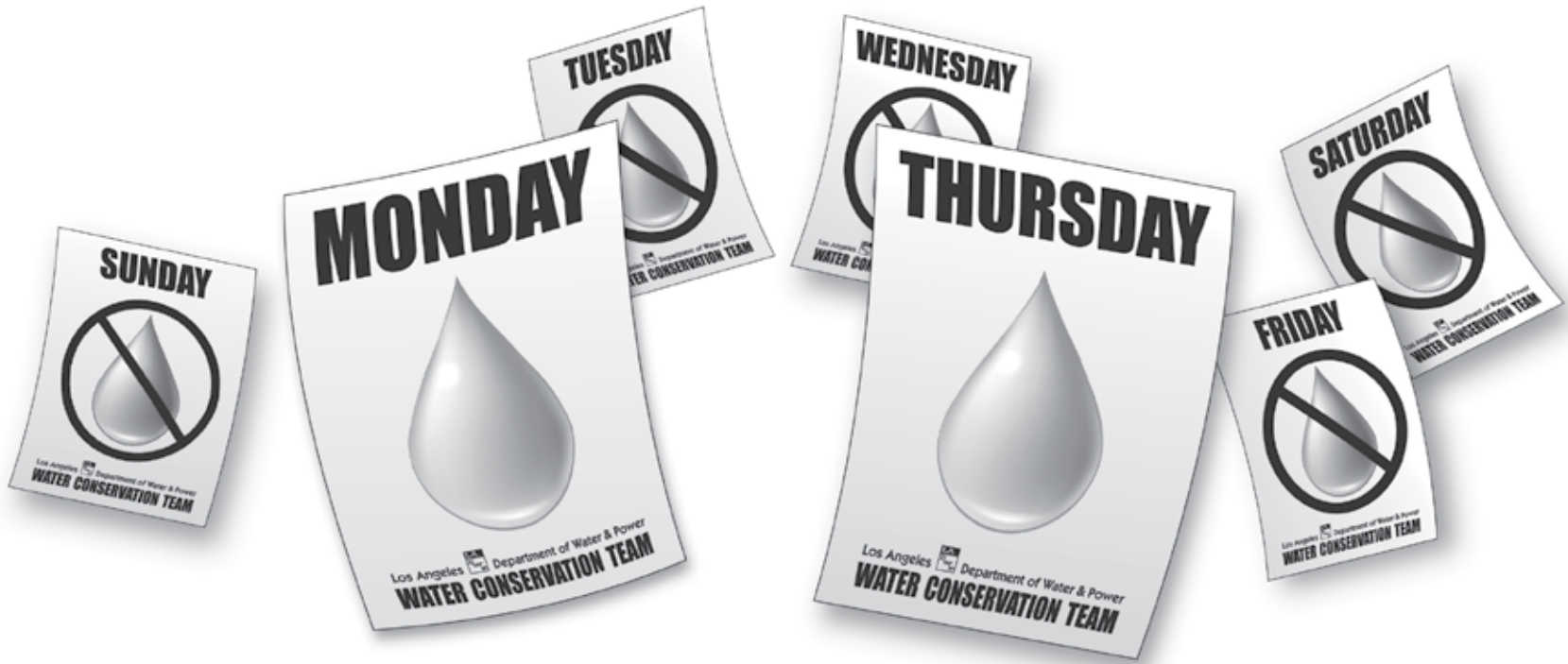

# MANDATORY WATER CONSERVATION

## EFFECTIVE JUNE 1<sup>st</sup> SPRINKLER USE IS RESTRICTED TO MONDAYS AND THURSDAYS

### Under The City's Water Conservation Ordinance It Is Illegal To...

- Water using sprinklers on any day other than Monday and Thursday
- Water landscaping - including lawns - between the hours of 9 a.m. and 4 p.m.
- Water using sprinklers for more than 15 minutes per watering station, 10 minutes for other irrigation systems
- Use water on any hard surfaces such as sidewalks, walkways, driveways or parking areas
- Allow runoff onto streets and gutters from excessive watering
- Allow leaks from any pipe or fixture to go unrepaired
- Wash vehicles without using a hose with a shut-off nozzle
- Serve water to customers in restaurants unless requested

### ... And Violations Are Subject To Fines!

### How Much Can You Save?

There are many simple and effective ways to save water outside your home. These tips can help. For additional information, go to [www.LADWP.com](http://www.LADWP.com) or [www.bewaterwise.com](http://www.bewaterwise.com)

TIPS	GALLONS SAVED per month	DOLLARS SAVED <small>Based on water rates in effect as of April 2009</small>
Water your yard before 9 a.m. and after 4 p.m. to reduce evaporation	750	\$2.99
Install a smart sprinkler controller	1200	\$4.79
Use a broom instead of a hose to clean driveways and sidewalks	4500	\$17.95
Check your sprinkler system for leaks, overspray and broken sprinkler heads	510	\$2.03
Install covers on pool and spas to reduce evaporation	900	\$3.59

### Rebates Can Save You Even More:

For residential customers

High efficiency clothes washer _____	\$ 300
High efficiency toilet _____	\$ 100
Weather-based irrigation controller _____	\$ 200
Rotating nozzles (per nozzle) _____	\$ 7
Synthetic turf _____	80 cents per sq. ft.

For more rebate information visit [www.bewaterwise.com](http://www.bewaterwise.com).  
For a complete list of prohibited uses of water or to report water waste call 1-800-DIAL DWP or go to [www.LADWP.com](http://www.LADWP.com)

## Pediatric Dentistry



**Randall E. Niederkohr, D.D.S.**

**Dr. Luis Martinez**  
Orthodontist

**PH: (323) 463-8322**

**FAX: (323) 463-0937**

**321 N. Larchmont Blvd. #809**  
Los Angeles CA 90004



## St. Teresa of Avila Elementary School

"Where Faith and Knowledge Meet"

KINDERGARTEN through GRADE 8

- \* A Quality Catholic Education
- \* Educating the Whole Child
- \* Computer Classes/ Internet Access - K-8
- \* Spanish as a 2nd Language - K-8
- \* Academic Decathlon Team
- \* Extended Day Care
- \* Family/Parent Involvement
- \* An Excellent Academic Program
- \* Departmentalized Junior High
- \* Instrumental Music Program - K-8
- \* Varsity Sports Program
- \* Daily Hot Lunch Service
- \* A Caring Multi-Cultural Community
- \* Committed Qualified Teachers

FULLY ACCREDITED by WASC and WCEA

CALL FOR OPEN HOUSE APPOINTMENT

FAITHFULLY SERVING the COMMUNITIES of SILVER LAKE, LOS FELIZ, ATWATER, EAGLE ROCK and GLENDALE for OVER 58 YEARS.

For more information please call, e-mail or visit our web site.  
2215 Fargo Street, Los Angeles, California 90039  
The corner of Glendale Blvd. and Fargo Street, where the 2 Fwy ends.  
Tel: (323) 662-3777 Fax: (323) 662-3420

E-mail: [cdbfc@stteresaofavilala.org](mailto:cdbfc@stteresaofavilala.org) | [www.stteresaofavilala.org](http://www.stteresaofavilala.org)

## Segray

Exploring A Child's Individuality



- \*Preschool Program starts at 18 months old
- \*Transition For Toddlers
- \* After school Program
- \* Parent and me class

3201 La Clede Avenue  
Los Angeles Ca 90039  
323-953-4878  
[www.segray.com](http://www.segray.com)

Lic.#198013596



**FRENCH AMERICAN SCHOOL**  
Since 1978

Pre-k through 12th Grade

Lycée International  
de Los Angeles

LILA emphasizes the acquisition of languages through immersion. Classes are taught in French and English.

- Preschool-12th grade in French and English on four campuses (Los Feliz, Pasadena, West Valley, Orange County)
- Excellent International Baccalaureate/French Baccalaureate/High school diploma college preparatory curriculum
- Low student/teacher ratio
- Athletic program : Soccer, Basketball, Volleyball, Cross Country and Baseball
- After-school activities : Basketball, Volleyball, Theater, Yoga, Guitar, Piano, Soccer, Judo, Tae Kwon Do, Art...
- Vacation Camps : Science Camp (February), Art Camp (April), Summer Camp (July)

Triple Accreditation:

- Western Association of Schools and Colleges (WASC)
- French Ministry of Education
- International Baccalaureate Organization - Geneva

**Los Feliz Campus**

4155 Russell Ave.  
Los Angeles, CA 90027

[Morgan.jeanne@lilaschool.com](mailto:Morgan.jeanne@lilaschool.com)

**(323) 665-4526**

DOWNLOAD OUR STUDENTS' PODCASTS IN FRENCH ON  
[WWW.LILASCHOOL.COM](http://WWW.LILASCHOOL.COM)

## Saint Brendan School Fundraiser, May 1st

St. Brendan School will host its annual Spring Fundraiser, "A Night in Rome Filled with Delicacies and Merriment," at Maggiano's Restaurant at the Grove, May 1st from 7 p.m. to 11 p.m. Tickets are \$50 per person, for dinner and one glass of wine.

Proceeds benefit St. Brendan School, which has served the Los Feliz and Hancock

Park community since 1912.

The school is in the midst of an expansion with a new building slated for completion by the fall, overseen by Monsignor Terrance Fleming.

St. Brendan School is located at 238 S. Manhattan Pl.

For information contact:  
[SBSMayFundraiser@gmail.com](mailto:SBSMayFundraiser@gmail.com).

[PILGRIM SCHOOL]

## Pilgrim School Honored On 50 Years

Mayor Antonio Villaraigosa has named March 20th as "Pilgrim School Day" in the city of Los Angeles. The school, located on Commonwealth Avenue, is celebrating its 50th anniversary.

"We are incredibly proud to have the city of Los Angeles declare March 20th to be 'Pil-

grim School Day" said Head of School, Mark A. Brooks. "We share this honor with every Pilgrim faculty member and student for the past fifty years."

The school was founded in 1958 by First Congregational Church of Los Angeles and serves grades preschool through 12th.

## Do You Have an Eastside Kid?



[www.eastsidekidsclub.com](http://www.eastsidekidsclub.com)

Join the Eastside Kids Club  
and start saving at all of these  
neighborhood stores!

[dragonflydulou.com](http://dragonflydulou.com)

[growkidgrow.com](http://growkidgrow.com)

[juvieshop.com](http://juvieshop.com)

[lalaling.com](http://lalaling.com)

Mila 323 661 2861

[monkeyhousetoys.com](http://monkeyhousetoys.com)

[reformschoolrules.com](http://reformschoolrules.com)

[unclejers.com](http://unclejers.com)

[wee-soles.com](http://wee-soles.com)

[yolk-la.com](http://yolk-la.com)

Register at any of these stores to  
receive your free Eastside Kids Club  
membership discount card.\* Every \$50  
purchase enters you in a raffle for 10  
gift certificates / \$250 total value.

\* 10% discount on regularly priced kids'  
merchandise; excludes furniture, art, classes  
and special orders.

## [IMMACULATE HEART] Mary, Mirror of the Light

By Suzie Shehayeb '10 and  
Anne Suh '10

Mary's Day is Immaculate Heart's most cherished tradition and occurs the first Friday of May — May 1st this year. This year the theme is "Mary, Mirror of the Light." A P exams are coming up in May and Immaculate Heart students will also be recognized for their academic achievements during the Academic Awards Night held later in the month.

Also this month, drama students will entertain friends, family and faculty during their drama finals performance. Later this month, works by students taking an art class will also be displayed in the auditorium during our annual art show. The furniture projects of the Drawing and Painting classes continue to hold the spotlight during this event.

## Marshall's New Track and Sports Field Underway

Los Angeles City Councilmember Tom LaBonge, along with Los Angeles Unified School District board member Yolie Flores Aguilar, broke ground in March for a \$7.8 million track and field expansion at John Marshall High School.

"This project is long overdue," LaBonge said. "When I played high school football in 1969 they planned to do this. I'm glad it's finally happening."

The construction includes a new football/soccer field and the completion of a 400 meter regulation track.

Construction is being funded by voter approved bond measures through LAUSD and the city of Los Angeles.

The expansion is expected to be complete for the upcoming fall football season.

## MOMS Club Rummage Sale

The Silver Lake MOMS club will host their annual rummage sale, Sunday, May 17th, from 9 a.m. to 2 p.m.

Items for children and adults will be available plus baked goods and drinks. 2580 Armstrong Ave.

Send the  
Los Feliz Ledger  
your School News to:  
[acohen@losfelizledger.com](mailto:acohen@losfelizledger.com)

# I ♥ Atwater Village

shop local



Unique Gifts from Exotic Places.  
Imported jewelry, accessories and home decor.

**\*Bring in this ad and receive 10% off your purchase!**

3149 Glendale Blvd.  
Atwater Village, 90039

\*Valid Until: 6/30/09

(323) 665-1901

www.importantegifts.com

3172 GLENDALE BLVD.  
LOS ANGELES, CA 90039  
323.661.7722

LA WEEKLY'S  
**2008**  
BEST OF THE BEST  
DOG FASHION

www.woofdogboutique.com

**20% OFF**  
ONE REGULAR PRICED ITEM  
WITH THIS AD.  
(DOES NOT INCLUDE DOG/CAT FOOD)  
OFFER EXPIRES 6-30-09

black maria  
store

Prints  
Toys  
Urban Vinyl  
Houseware  
T-shirts  
Accessories  
Giclee prints  
...and more

Bring this ad in for 15% off all items!

Black Maria Gallery Store  
3139 Glendale Blvd.  
Los Angeles, CA 90039  
info@blackmariagallery.com



**Sweets for the Soul**  
Handmade Desserts

Using only the finest ingredients  
No preservatives  
Made fresh daily

10% off your first  
purchase with this ad

3169 Glendale Blvd.,  
Los Angeles, CA 90039  
323-668-9338



KIDDING AROUND THE KITCHEN®

Presents

Japanese American National Museum

April 11, June 6, August 29, Oct 24 and Dec 5 2009: Family Cooking  
Classes and workshops at the JANM. JANM and Kidding Around the Kitchen  
are offering different themed hands on cooking classes for the whole family.

For information call phone: 213-625-0414 or check out the website <http://www.janm.org/events/>

[www.kiddingaroundthekitchen.com](http://www.kiddingaroundthekitchen.com) • 323 371-9269 • [lisafontanesi@yahoo.com](mailto:lisafontanesi@yahoo.com)  
Call or email for pricing on private/group cooking classes

Amelia FITZWATER  
• a classic gift boutique with retro flair •

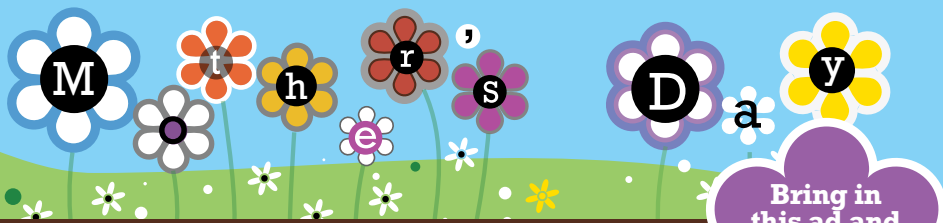

an eclectic mix of books, gifts, paper and accessories

Located in Atwater Village • 3129 1/2 Glendale Blvd, L.A., CA 90039  
323-661-2600 • Open Tues-Sat 11-7 and Sunday 11-5 valid until 6/30/09

Bring in  
this ad and  
receive  
10% off your  
purchase!

VIA ROMI SALON

3129 Glendale Blvd. Atwater Village, CA 90039

HAIR BY JANELLE ROMI RIOS

Thermal conditioning treatment, haircut  
and style \$45 or take \$20 off any color  
and cut with this ad.

Call for an appointment:  
626-644-6529 [www.hairbyjanelle.com](http://www.hairbyjanelle.com)

Facials  
Full Body Waxing  
Mirco-dermabrasion  
Eyelash Perms  
Eyelash Extensions

323-661-SKIN (7546)

**\$10.00 off**  
with this coupon.  
Expires July 10, 2009

Violet  
Willow

Store Hours: Tues-Sat 12-7

Come and be inspired by our visually exciting space. Featuring the latest in  
unique women's apparel, accessories and home decor at attractive prices.

3127 Glendale Blvd.,  
Los Angeles, CA 90039  
323 906 2943

email: [violetwillowboutique@yahoo.com](mailto:violetwillowboutique@yahoo.com)

Mention this ad and enjoy 20%  
off your total 1st time purchase!

Offer Expires: 6/30/09

Movements Boutique has clothing and accessories for the modern woman on the move!

Store Hours Tues - Sat 12 to 7 and Sun. 12 to 5

MOVEMENTS

Get 10% Off With This Coupon

Movements is a place for fun, check out the events hosted by Movements the last  
Saturday of every month! For more information go to [www.movementsboutique.net](http://www.movementsboutique.net)

3125 Glendale Blvd., LA, CA 90039 ♥ 323-906-1805 (Offer Expires August 31st, 2009)

Auto • Home • Life • Workers' Compensation

Sean Paul  
INSURANCE AGENCY

CA Lic # 0C20097

Sean Paul Labrecque  
bus 323.667.9180

3101 Silver Lake Blvd., Los Angeles, CA 90039 | [sean@seanpaulins.com](mailto:sean@seanpaulins.com)



TUE-FRI 11-7  
SAT-MON 11-5

Mila - A boutique for little tots offers a mixture of  
eclectic clothing, accessories, & toys for your little  
ones to look adorable & hip, all at the same time.

3121 Glendale Blvd.  
Los Angeles, Ca 90039  
323-661-2861

Bring in this ad and we will take  
care of the SALE TAXES for you!

Valid Thru 6/30/09

[PEOPLE IN MY NEIGHBORHOOD]  
**Local's Book Helps Unlock  
 Mysteries of Math**

By Colleen Paeff, Ledger Columnist

**SILVER LAKE**—R.J. Toftness was never a math whiz. Sure, he passed math—all the way through calculus—but it wasn't until he became a teacher, and later a private tutor, that he gave the subject much thought.

"I noticed that the kids were having such a hard time

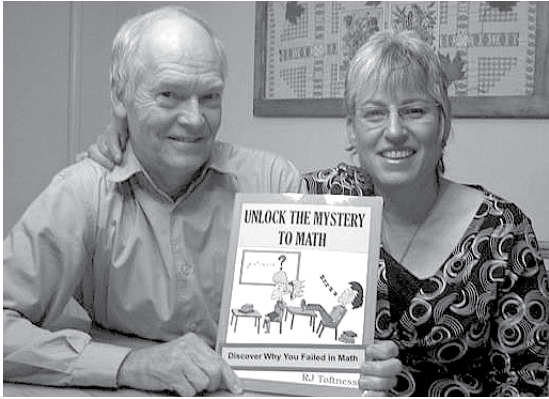

R.J. Toftness with wife, Michal.

with math," he said. "It wasn't like that when I was in school. Today's students seemed to be missing something."

Toftness set out to discover the missing ingredient. He compared the math books of his childhood with the math books of today and noticed one glaring omission: the word arithmetic.

"The word arithmetic," Toftness said, "started disappearing from textbooks in the mid 1960s, just as math test scores started to slip."

Why is the word so important?

Toftness believes that students will "drown in an ocean of data and facts" if the branches of math are not divided up into bite-sized

chunks. When arithmetic, the branch of mathematics dealing with numbers, is split

into ten tasty morsels (adding, subtracting, multiplying, dividing, fractions, percentages, decimals, counting, measuring and problem solving) it's much easier to grasp, he said. And with a firm foundation in arithmetic, students are more likely to excel in the other branches of mathematics: algebra, geometry and calculus.

For some time, Toftness toyed with the idea of writing a math book that would give an "overall picture of math" using stories and simple illustrations. Then, at 2:30 a.m. in February of 2008 inspiration struck.

He jumped out of bed and started writing what would become "Unlock the Mystery to Math: Discover Why You

Failed in Math."

His wife, Michal, provided the illustrations, and together, with a copy of Dan Poynter's Self-Publishing Manual, the couple delved into the world of self-publishing.

"We learned so much," Michal said. "There were a lot of sleepless nights. Sometimes for happy reasons, sometimes not."

After just over a year of

writing, illustrating, getting feedback, rewriting and learning about color separation, printers, and more, the book was finally released last month. It's already in use at a few schools in Wisconsin, Southern California, and, of course, in Toftness's own tutoring practice, where he said both adults and children are receiving phenomenal results.

"I want to bring out a willingness in the student to search the subject," Toftness said. "It shouldn't be forced. No one ever learns when it's forced. If I achieve that, then I feel like I've made my mark."

The book is available locally through the Los Angeles Public Library, at Chevalier's Books in Larchmont Village and online at [www.math-unlock.com](http://www.math-unlock.com).

**Po-ten-tial; (v)**—existing in possibility, capable in development into actuality

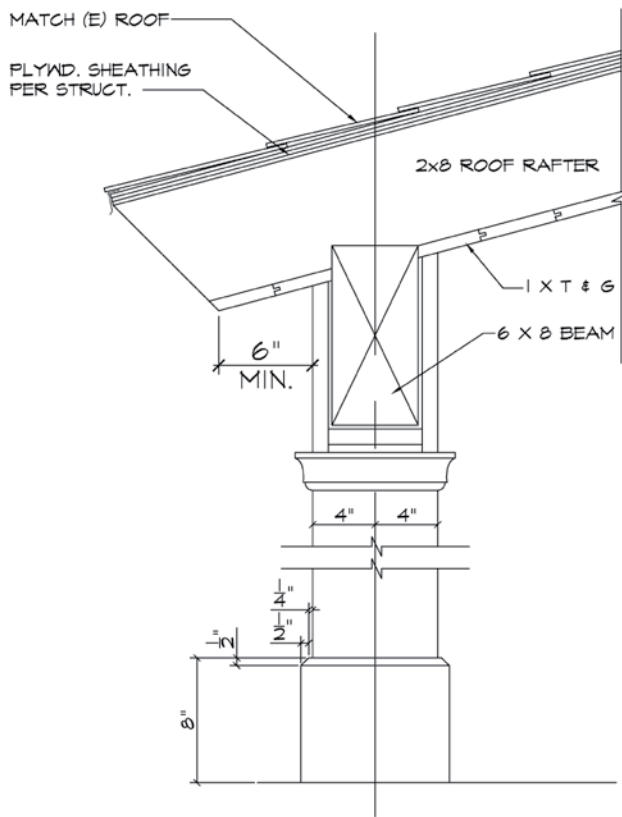

**Have you explored your home's potential?**

Many area homes have potential for greatness! As beautiful as their early design are, things are different today. Technological advancements, energy efficiency and lifestyles have progressed tremendously.

To bring your home's 21<sup>st</sup> century potential forward, I strive to find the balance between possibilities and actualities. It is possible to have a modern, efficient home without compromising the original character.

Hiring a Design team is a daunting task, one I wish to ease—to simplify. There is no obligation, no contract and no fee to discuss what your desires are—just the opportunity for me to share my thoughts and abilities with you.

Call me to explore your home's potential.



**Scott Design Group, Inc.**  
 323-896-6055  
 FAX 323-663-4921  
[Scott@ScottDesignGroupInc.com](mailto:Scott@ScottDesignGroupInc.com)

**Choose your discount**

**\$5 off \$20 order**  
 Dry cleaning incoming order only

**\$1 off each garment**  
 Dry cleaning incoming order only

1 2 3 4 Good for 4 uses  
 Exp. date: 6-30-09

**Free pick-up & delivery, just give us a call!**

**Los Feliz CLEANERS**  
 Mon - Fri... 7am - 7pm  
 Saturday... 8am - 6pm  
 Sunday... Closed  
 1922 Hillhurst Ave.  
 Los Angeles, CA 90027  
**323-665-0737**

**\$49.00**  
**drain cleaning**  
**from NHK Plumbing**

call for details  
**323 669 5222**  
 license #875792 insured and bonded

**Fine Rug Cleaning & Care**  
 Since 1920



Our hand-controlled process, assures full restoration & sheen



Slow Drying - All rugs dried in dust free, temp. controlled environment.



Repairs - Our team of experts will be happy to repair your rug to its original condition.

**SPRING CLEANING SPECIAL 20% DISCOUNT**

"Voted best rug cleaning by LA MAGAZINE"

"Environmentally safe rug cleaning. Allergen and bacteria free rugs in your home"



**Thomas Rug Cleaning Co. and ARARAT Oriental Rugs**

**For all your rug needs... call the best**

3000 Riverside Dr. LA, CA 90039  
**800-259-9929**  
**323-660-7388**  
[www.thomasrugcleaning.com](http://www.thomasrugcleaning.com)



# & Su Casa &

The Real Estate Guide for the Los Feliz Ledger



**SELECTED PROPERTIES**

*Local Experts Worldwide*



**OLD HOLLYWOOD MEETS 21ST CENTURY:** Los Angeles. Resort style gated estate on +/- 1 acre. Wonderfully remodeled w/ gstr hs, pool hs w deck, cabana, tns crt. Ocn & mntn vws. \$8,750,000 WEB: 0342271 Paula Ross Jones 310.880.9750



**LAUGHLIN PARK RETREAT ON CUL-DE-SAC:** Los Feliz. Luxuriance of living in this one story, 3bd, den, 3 1/2 ba, family room, pool home. \$2,849,000 WEB: 0283588 Tabakian & de Winter 323.376.2222



**2523 WILD OAK DR:** Los Feliz. Mid-century vu hm in Los Feliz Oaks. 3bd/3ba hm has unobstructed vus of Hillywd sign. Visit www.TimHartley.net for pics. \$1,369,000 WEB: 0283615 Tim Hartley 310.770.5168



**GREAT OPPORTUNITY IN THE OAKS:** Los Feliz. 3bd/2ba. Classic Mid-Century w/ pool. Gorgeous hdwd. Flrs. Stunning fpl, new kitchn. & appliances, entertainers dream. \$1,200,000 WEB: 0283539 Scott Cain 323.791.5341



**1915 N. NORMANDIE AVE:** Los Feliz. C. 1950 Artful presentation of a classic Mid-century. Designer finishes, updates & upgrades thru-out. Pool. Turn key! \$1,149,000 WEB: 0283519 Andrew Morrison 323.270.2277



**2501 KENILWORTH AVE:** Silver Lake. Gorgeous 3bd/2ba Spanish w/ a dramatic step down liv rm & soaring ceilings, sep fam rm + office. Lush yd, Ivanhoe Schl, \$1,099,000 WEB: 0283614 Karen and Marc 323.804.8043



**2171 W. SILVER LAKE DR:** Silver Lake. Amazing lake views from this stunning 3/2 Tudor, updated systems, modern touches, Ivanhoe School! www.2171SilverLake.com \$1,069,00 WEB: 0281506 Karen and Marc 323.804.8043



**1936 SPANISH COLONIAL:** Glendale. Formal Liv, hdwd flrs, fpl, stained glass, updated kit, bkfst rm, mstr suite, pool & spa, lrg patio 2,822 sqft, 8,700 lot. \$1,069,000 WEB: 0283594 Troy Gregory 323.203.5661



**1407 MCCOLLUM ST:** Silver Lake. Spanish 3bd/1.5ba plus 1br/1ba guest hse or office, light & bright, lrg rms, hdwd floors, patios, views, period details. \$875,000 WEB: 0283607 Joseph Lightfoot 213.700.4438



**2917 LAWDALE:** Eagle Rock. Spacious 60's trad split-level in desirble hillside pocket. 4+1.75 + family rm opn to kit + patios. www.2917lawndale.com \$643,000 WEB: 0283608 J. Martinez / A. Morrison 323.377.0548



**PICTURESQUE BUNGALOW:** Echo Park. Gated romantic gem on neighborhood's most desirable street. Extensive renovations and upgrades. www.2030cerrogordo.com \$599,000 WEB: 0283609 Andrew Morrison 323.270.2277



**LAGO VISTA TOWNHOUSE:** Silver Lake. Bright corner location townhouse Classic arch'l style. Pool, vistas, gated secluded, all amenities. Allyn E. Morris, Arch. \$464,000 WEB: 0283611 Peter Reyes 323.671.2359

**SOUTHERN CALIFORNIA BROKERAGES** | [SOTHEBYSHOMES.COM/SOCAL](http://SOTHEBYSHOMES.COM/SOCAL) | USE THE WEB NUMBERS PROVIDED TO FIND OUT MORE INFORMATION ON A PROPERTY THROUGH OUR WEBSITE

**LOS FELIZ** 1801 NORTH HILLHURST AVENUE T 323.665.1700

BEVERLY HILLS | BRENTWOOD | HOLLYWOOD BEACH | LOS ALAMOS | LOS OLIVOS | MALIBU | MONTECITO  
PACIFIC PALISADES | PASADENA | SANTA BARBARA | SANTA MONICA | SANTA YNEZ | SUNSET STRIP | WESTLAKE VILLAGE

©2008 Sotheby's International Realty, Inc. is Owned and Operated by NRT LLC. Sotheby's International Realty® is a registered trademark. La Villa Bleue used with permission. Sotheby's International Realty does not guarantee the accuracy of square footage, lot size or other information concerning the property provided by the seller or obtained from public records or other sources.

[REAL ESTATE]

**Is 2009 Your Year to Buy?**

By Richard Stanley



The “perfect storm” of recent financial turmoil has also generated a perfect opportunity that many would-be homeowners are now pursuing. When can anyone recall a confluence of historically low interest rates, declining home prices, government-sponsored purchase incentives and ample inventory?

Here are some of those incentives that might convince you that 2009 is your year to buy:

**\$8,000 First-Time Buyer Tax Credit** – Part of President Obama’s stimulus bill provides first-time buyers an \$8,000-dollar tax credit on the purchase of a primary residence. A “first-time buyer” is defined as a buyer who has not owned a principal residence during the three years prior to the purchase. Purchases must be made between January 1st and December 1st, 2009. To qualify, a single person may not earn more than \$75,000 per year, or a married couple may not earn more than \$150,000 per year.

**\$7,500 First-Time Buyer Tax Credit** – For first-time home buyers who purchase a principal residence between April 9, 2009 and before July 1, 2009, the Federal Government will allow a \$7,500 tax credit. Unlike the \$8,000 tax credit above, it must be repaid over a 15-year period.

Effectively, it’s an interest-free loan. Income qualifications are the same as for the \$8,000 credit.

**State Tax Credit** – Buyers of new homes in California after March 1, 2009 and before March 1, 2010 qualify for a state tax credit signed by Governor Schwarzenegger this past February. Under this law, a taxpayer may purchase one qualified principal residence that has never been occupied—resales are not qualified. The credit is determined as the lesser amount of 5% of the purchase price or \$10,000. The credit must be claimed in equal amounts over a three-year period, beginning with the tax year in which the purchase is made. Further, the buyer must occupy the home for at least two years immedi-

ately after the purchase. Availability of this program ends when a pool of \$100 million in state funds is exhausted.

**FHA Loans** – The Federal Housing Administration (FHA) offers 3-1/2 % down payment loans on the purchase of homes within certain maximum purchase price limits. Mortgage insurance is required.

**Mortgage Credit Certificate (MCC) Program** – The City of Los Angeles Housing Department has a Mortgage Credit Certificate (MCC) program for first-time buyers to assist buyers qualify for a mortgage. The program offers a 15% mortgage tax credit (or 20% for “targeted areas”—Los Feliz, Silver Lake, Echo Park are not “targeted areas”). Buyers’ maximum annual earnings may range from \$88,000 to \$103,000 depending on its location and the number of purchasers. The price of a qualifying house may range from \$571,000 to \$722,000, depending upon the location of the house and whether it is old or new construction.

**Purchase Assistance Financing** – The City of Los Angeles Housing Department offers purchase assistance financing to eligible low and moderate-

income homebuyers seeking to purchase a foreclosed home in a “Neighborhood Stabilization Program Priority Area.” The program provides a deferred loan for purchase assistance (acquisition, down payment and closing costs) and rehabilitation funds.

Finally, even the US Department of Agriculture offers a program of 100% financing

on owner-occupied loans in designated rural areas. Many small towns and rural areas of California qualify.

With all this help around, who wouldn’t want to buy a house in 2009?

*Richard Stanley has been the top agent at the local Coldwell Baker office since 1995. www.richardstanleyrealtor.com*

**No job is too big or too small.**  
From faucets to water heaters we do it all.

**senior discounts**

**\$85 Special**  
drain cleaning with free sewer camera inspection!

**family owned and operated**

We specialize in sewers and drains. Gas, sewer, and copper repipes. We do our own trenchless pipe replacement and copper repiping.

State licensed for plumbing C-36, and Sanitation C-42. Bonded & Insured.

877-840-8842

**COLDWELL BANKER** RESIDENTIAL BROKERAGE

**MAXIMUM EXPOSURE ONLINE**

Coldwellbanker.com • Californiamoves.com Realtor.com • LATimes.com • Openhouse.com  
1917 Hillhurst Avenue • Los Angeles CA 90027 • Office: (323) 665-5841 • Fax: (323) 666-4955



**25% SOLD LARCHMONT**

**5037 ROSEWOOD AVE** Prices From \$500,000's  
Escape to a private retreat in Larchmont Village. A breathtaking collection of 2BD/2BA homes with fountain courtyard, gated entry and parking, living rooms with hardwood floors and fireplace, spacious bathrooms with tumbled limestone, custom kitchen cabinetry along with stainless steel appliances.

CLAUDIA HIPOLITO www.5037Rosewood.com 323-906-2424



**LOS FELIZ**

**2035 DEMILLE DRIVE** \$2,595,000  
You loved it before, & you'll have to have it now, after a nearly \$2 million price drop! Limestone and walnut flooring casts notes of elegance & luxury throughout this sleek, freshly-"done", pristine Modern villa behind the gates of storied Laughlin Park. 4 bdrms; 5.5 baths; media & family rms; bar; gym; office; detached guest house over 3-car garage w/gated motor court; swimmer's pool; spa; luxuriant foliage everywhere.

RICHARD STANLEY www.DeMille2035.com (323) 906-2417



**LOS FELIZ**

**4969 AMBROSE AVENUE** \$1,049,000  
Sunny '20s Mediterranean villa on one of Los Feliz's most picturesque streets. Lg. rms, hi ceilings, French windows and drs. Full-width living room with fireplace; master bedroom suite + 2 bedrooms all on second floor. Mostly flat lot. Updated. Detached 2-car garage, long driveway!

RICHARD STANLEY rstanley@richardstanleyrealtor.com (323) 906-2417



**LOS FELIZ**

**3726 EFFINGHAM PLACE** \$999,000  
Wow-When was the last time you saw a house north of the blvd. at this price? Hurry this beauty won't last. 3 Bedrms 2 baths, amenities include lrg living rm & sunroom w/view deck, family rm, formal dining rm & eat-in kitchen. Beautifully landscaped yard features waterfall, areas for entertaining, 2 car garage, & more!

CHRIS ABBOTT & FRANS SIMSON fsmson@coldwellbanker.com (323) 210-1430



**LOS FELIZ**

**3794 AMESBURY ROAD** \$6,200 mo.  
Historic Hollywood celebrity retreat high atop the Los Feliz hills. Unique and abundant character details; updated. 4 BR + 4BA. Mature landscaping with expansive lawn afford celebrity-level privacy. Available long- or short-term / unfurnished or partially-furnished

RICHARD STANLEY rstanley@richardstanleyrealtor.com (323) 906-2417



**LINCOLN HEIGHTS**

**3102 BALDWIN STREET** \$216,900  
This classic Victorian is awaiting restoration. 4 bedroom and 1 bath good size home with old world charm has many original details

LORI RAMIREZ lramirez@coldwellbanker.com (323) 210-2400

©2008 Coldwell Banker Real Estate LLC. Coldwell Banker® is a registered trademark licensed to Coldwell Banker Real Estate LLC. An Equal Opportunity Company. Equal Housing Opportunity. Owned And Operated By NRT LLC. Broker does not guarantee the accuracy of square footage, lot size or other information concerning the condition or features of property provided by seller or obtained from public records or other sources, and the buyer is advised to independently verify the accuracy of that information through personal inspection and with appropriate professionals

**[CITY SLEUTH]**  
**Seligman's Los Feliz**  
 by Diane Kanner, Ledger Columnist



In 1979, Donald Seligman's post doc UCLA dental students started him on a quest that became a passion—and it wasn't dentistry.

"We hear there's a downtown," they said jokingly to the professor. And the search for Los Angeles city history, for Seligman, was on.

He dug into family papers and uncovered films of long ago picnics in Griffith Park. When he retired from medicine in 1996, he became a member of the Los Feliz Improvement Association's (LFIA) history committee.

A computer whiz, he scanned thousands of photos the committee had taken of Los Feliz homes before tackling census data of the same properties. His expertise allowed the LFIA to complete its monumental historic resources survey that is today housed at the Los Feliz branch library.

With the help of fellow local historians on the LFIA committee, his efforts grew a photo archive from 300 to 1,100 images.

"It should be shared," he said of the collection.

But Seligman could not be stopped. Confined to home for a month with a back problem, he wrote the history of Los Feliz.

"About two billion years ago," it begins in typical Seligman exhaustive style, echoing James Michener's saga genre.

The LFIA published his book recently, and the author has been on the speaking circuit. He describes Jose Vicente Feliz, namesake of Rancho Los

Feliz, as "the guiding spirit of the new pueblo" of Los Angeles.

Feliz was "one of the most intelligent residents" of that late 18th century settlement and was rewarded for his efforts as a soldier with the position of city manager.



Donald Seligman

"You would not want to have lived here before 1821," Seligman tells audiences, for the transition from Spanish to Mexican rule brought on "turbulent times," not the least of which were legal rulings invalidating claims of many settlers,

include the Feliz's.

For a copy of "Los Feliz: An Illustrated Early History," visit Skylight Books on Vermont Avenue or contact the LFIA at their website.

**[KEEN TO BE GREEN]**  
**Thrifty Threads**  
 By Meher McArthur  
 Ledger Columnist



Like many, I am trying to consume less and watch my budget in these shaky economic times. But, I do often get the urge to treat myself to new clothes or shoes. I used to feel a bit wasteful and materialistic when I bought a fancy new outfit, but now I have found a much "greener" way of buying new clothes—new to me, at least.

A while ago, when I visited my local thrift shop, Out of the Closet in Atwater Village (www.outofthecloset.org), I was thrilled to discover that someone who is my size and has my taste in clothes is giving great clothes regularly to this terrific organization. I almost always find what I am looking for—black pants before a big trip, a designer dress for a bridal shower, cashmere sweaters – barely worn, great quality and under \$10! Now, I

have trouble shopping in regular clothing stores. Increasingly, I find that when I reveal the source of my "new" threads,

the Goodwill on Sunset near Vermont (www.goodwill.org); Squaresville on Vermont in Los Feliz (www.myspace.com/

**Increasingly, I find that when I reveal the source of my "new" threads, friends confess that they too bought their clothes at similar stores...**

friends confess that they too bought their clothes at similar stores, like Berda Paradise at 3506 W. Sunset Blvd. in Silver Lake (benefits the Hollywood Sunset Free Clinic);

squaresvillevintage), or even yard sales.

Now, my shopping is relatively guilt free. I am not only spending less and helping a good cause, but I'm also recycling.

**A-1 BEST CHOICE CONCRETE**

Big and Small Jobs | All Concrete Work

State Lic. #8030044

Foundations, Seismic Retrofitting, Concrete Slabs, Patios, Driveways, Sidewalks, Walkways, Curbs, and Steps  
 Railroad Tie Walls

Free Estimates

(323) 660-7463



full service design firm  
 from consultations to remodels



jeff lewis  
 design

323.960.8500  
 www.jefflewisdesign.com

**[ SELECT HOME SALES MAY 2009 ]**

**90026 Single Family Homes**

3530 CARNATION AVE .....	\$975,000
1806 EFFIE ST .....	500,000
1512 MORTON TER .....	360,000

**90027 Condominiums**

4711 AMBROSE AVE 104 .....	\$510,000
----------------------------	-----------

**90027 Single Family Homes**

2451 CHISLEHURST DR .....	\$2,407,000
5054 LOS FELIZ BLVD .....	1,640,000
2303 WAYNE AVE .....	977,500
1957 MYRA AVE .....	885,000
2441 LYRIC AVE .....	850,000

**90039 Single Family Homes**

1954 MICHELTORENA ST .....	\$1,890,000
2347 MORENO DR .....	1,626,000
2358 EDGEWATER TER .....	800,727
3239 HOLLYDALE DR .....	595,000

**90068 Condominiums**

2222 N BEACHWOOD DR 302 .....	\$552,000
-------------------------------	-----------

**90068 Single Family Homes**

7261 OUTPOST COVE DR .....	\$2,587,500
2284 W LIVE OAK DR .....	2,000,000

Sales are from the previous month. Source: Great American Real Estate Solutions

**Landscape Contractors**  
 Ca Lic #537590

Design  
 Installation  
 Hardscapes  
 Irrigation  
 Hillsides

**Plant Systems**  
 323-664-6133  
 www.plantsystems.info



LEADING REAL ESTATE COMPANIES OF THE WORLD™

# NOURMAND & ASSOCIATES

6525 Sunset Boulevard, 8th floor  
Los Angeles, California 90028  
tel: 323.462.6262  
www.Nourmand.com

Locally owned and operated since 1976.

**Howard Lorey**

**Branch Manager**

**direct:**

323-462-6262

**email:**

hlorey@nourmand.com



### FOR SALE

**100 S. Hudson Pl. - \$7,450,000**  
*Hancock Park.* Exquisite 1929 Federal style never on market, 1/4 acre grnds, 4BR/6BA, grmt kitchen, gracious master suite.  
**Myra Nourmand 310.888.3333**  
**Melody Rogers 310.888.3357**



### NEW LISTING

**3045 Hollyridge - \$2,495,000**  
*Hollywood Hills.* Mediterranean estate with gardens, expansive yard with pool and outdoor fireplace/patios. 6 bedrooms, 5.5 baths.  
**Jim Crane 310.855.4595**  
**Kathryn Shafer 323.376.9601**



### FOR SALE

**10857 Willowcrest - \$950,000**  
*Studio City.* South of the Blvd. Wrightwood estates without the traffic. Updtd & landscaped w/pool. FLR, FR, 2 FP's, 3BR/1.75BA.  
**Scott Campbell 323.252.9870**



### FOR SALE

**2166 Echo Park Ave. - \$850,000**  
*Echo Park.* 3 units - Amazing renovated turn of the century Bungalows, 2BR/1BA house + duplex. Perfect for owner occupied buyer.  
**Howard Lorey 323.251.4553**



### FOR SALE

**3423 Greensward - \$699,000**  
*Atwater Village.* 3BR/3BA, Completely rebld frm the ground up, new operating systms, wlk to shops, restaurants & farmers market.  
**Courtney Smith 323.899.8509**



### FOR SALE

**The St. Regis Hotel - \$549,000**  
*Manhattan, NY.* Own a piece of a Manhattan landmark. Fractional 1/12 ownership. Furnished 2BR/2BA.  
**Robert Mobley 323.462.6262**  
**917.549.8767**



### FOR SALE

**7135 Hollywood - \$549,000**  
*Hollywood Hills.* Modern 2BR, 2BA designer done in lux hi-rise bldg., top of the line kit & baths. 24hr drman, sec & valet prkng.  
**Beverly Shea 310.487.0395**



### FOR SALE

**5207 Palmero - \$529,995**  
*Mt. Washington.* Mid-Century 3BR/2BA, hrdwd flrs, updtd kit & cozy den. Panoramic views & Mt. Washington School District.  
**Strahil Goodman 323.842.8899**



### PENDING

**1917 N. Gramercy - \$1,089,000**  
*Hollywood Hills.* Exceptional Bronson Hills Craftsman showcasing original period details. 3 bedrooms plus library, 1.5 baths and park-like backyard.  
**Courtney Smith 323.899.8509**



### PENDING

**960 Larrabee #318 - \$299,000**  
*West Hollywood.* Top flr, bright & light 1BR/1BA. Spanish tile, spa tub, needs TLC w/views of the Hills. Bldg allows pets & wd flrs.  
**Jason Callaway 310.880.8020**



### JUST SOLD

**3530 Carnation**  
*Silverlake.* Represented Buyer. Eclectic 1920's hillside Traditional immaculately updated. Fireplace, views and huge yard with pool.  
**Offered at \$999,000**  
**Norm Kerner 323.330.6666**



### JUST SOLD

**1022 Hyperion Ave.**  
*Silverlake.* Represented Buyer. 2 houses on a lot, 3BR/2BA in main house plus 1+1 guest-house. Walk to Sunset Junction.  
**Offered at \$799,000**  
**Howard Lorey 323.251.4553**



### JUST SOLD

**1939 Rosalia Rd.**  
*Los Feliz.* Represented Buyer. 1936 Spanish loaded w/original details. Open beamed ceilings, FP, hrdwd flrs & stained glass windows.  
**Offered at \$778,900**  
**Michele Hess 213.700.1372**



### JUST SOLD

**7901 Denrock**  
Represented Buyers. 1940's Traditional, 2 bedroom, 1 bath, hardwood floors, fireplace and huge yard.  
**Offered at \$649,000**  
**Matt Boyd 323.646.4256**

We Market Your Home To The World



**[SENIOR MOMENTS]**  
**A Real Challenge—Fixing Our Health Care System**  
 By Stephanie Vendig, Ledger Columnist

Lately, we've heard a lot about the possibility of "health care reform." Our current system really does need fixing. We spend nearly twice as much per capita as other countries in the industrialized world, yet have lower life expectancy and higher mortality rates among children (*AARP Bulletin*, April 2009). And 15% (46 million) of the population can't take advantage of this system

because of lack of insurance.

Health care reform will focus on high costs, and unequal access, each with its own solutions and political dilemmas. But, for sure, we will not be able to solve one without solving the other. And do you do both at the same time, simultaneously, or do you have to do one before the other?

*Washington Post* correspondent, T.R. Reid, was on *PBS*

*Frontline* last year in the broadcast, "Sick around the World." He shared his observations about the health systems of five countries—Britain, Japan, Germany, Switzerland and Taiwan—all having universal access to health care. Within each of these countries, he found out how they manage their systems and how they were different from ours. His upcoming book on international health care, titled "We're Number 37!" referring to the ranking of the U.S. in the World Health Organization 2000 World Health Report will publish in August, 2009.

There are only two pure "socialized medicine" models in the world. One is Cuba and the other is our own VA system serving our veterans. All the rest are combinations of private and public entities. Reid found that most follow one of four basic patterns, each having a different way of incorporating competition and choice. He learned that all capitalist democracies do not trust health care entirely to the

free market, they impose limits. For us, a patchwork of systems for separate classes of people produces unequal access, whereas for about 40 countries of the developed, industrialized world with health systems, one model is used to make sure everyone has access. Having one model means fairness, accessibility for all, lower administrative costs and is generally cheaper.

**FABULOUS SILVER LAKE HOME FOR SALE**



**GAIL CROSBY**  
**(323) 428-2864**

For more photos go to:  
[www.GailCrosby.com](http://www.GailCrosby.com)



**Prudential California Realty**  
 Seniors Real Estate Specialist (SRES)  
 and Eco Broker Designation

**2382 Kenilworth Avenue, Los Angeles, 90039, \$935,000**

**Looking for the Silver Lake lifestyle?** Home is a beautiful retreat in the best part of Silver Lake. Cook like a pro in the chef's kitchen with a built-in couch and plenty of storage. Enjoy a glass of wine on the fabulous deck. Plant a garden in the huge backyard. Room to expand. Home is restful with plenty of natural light. Glass block windows, end high appliances, and views. Great home for entertaining. See lots of pictures at [GailCrosby.com](http://GailCrosby.com)

**Griffith Park Adult Community Club Calendar**

**General Meeting, May 20<sup>th</sup>, Friendship Auditorium, 12:00 noon - 3:00 pm.**  
 Program: A Brass Ensemble from UCLA Music Department and a presentation by the staff of Kaiser Hospital on the latest trends in medical practices including features of their new expanded hospital.

**For trips, Call Doris Slater at (323) 667-1879 for information on new trips.**

**Classes**  
 Contact Griffith Park Adult Community Center (GPACC) at (323) 644-5579 or stop by at 3203 Riverside Dr., in the parking lot of Friendship Auditorium south of Los Feliz Blvd to get a schedule of classes and events.

Silver Lake Recreation Center at 1850 W. Silver Lake Dr. (323) 644-3946 will also have classes.

**The Lunch Program:** Lunch is served 5 days a week at the Center. \$1.75 is a donation for those over 60 years. Daily lunch is served at 12 noon and you can come in for coffee and sign in at 11:30. If you are going to attend the May meeting, call GPACC the week before the meeting to let us know you are coming.

For Information on the Griffith Park Adult Community Club and getting a newsletter, call Stephanie Vendig at (323) 667-3043, or e-mail at [vendig@sbcglobal.net](mailto:vendig@sbcglobal.net) or call Jeanne Phipps at (323) 664-2681.

**Programs for Free-Thinking Seniors!**  
 To learn more about our current calendar of classes, concerts and cultural events, visit [www.sunsethall.org](http://www.sunsethall.org). For information: Wendy Caputo (323) 962-5277



**"I choose to stay connected."**

*"When my son and his family moved out-of-state, I worried that we would lose touch. But thanks to Belmont's Center for Learning, we're more connected than ever. I even get e-mail from my grandchildren! Plus, I always have lots of pictures to show my friends. The Belmont Village Activity Programs Coordinator got me up to speed in no time, on computers designed especially for me. Now my grandkids can't believe I'm surfing the web and I can't believe how easy it is!"*

**"I Choose Belmont Village"**

- Chef-prepared, restaurant-style dining
- Free scheduled transportation daily
- Fitness and social activities
- Licensed nurse on-site around the clock
- Medication management
- Housekeeping and laundry
- Assistance with daily living
- Circle of Friends® memory program
- Short-term stays available
- Specialized Alzheimer's care

**BELMONT Village**  
 ASSISTED LIVING

Burbank (818) 972-2405  
 Encino (818) 788-8870  
 Hollywood Hills (323) 874-7711  
 Rancho Palos Verdes (310) 377-9977  
 Opening Summer 2009 Westwood (310) 475-7501



RCFE Lic 197603515, 197603848, 197605090, 198204246 © 2009 Belmont Village, L.P.

**Call 866-905-2266 or visit [www.belmontvillage.com](http://www.belmontvillage.com) to order your free guide to Assisted Living**



**Autry National Center**  
of the **American West**

# Sparkle & TWANG

**Now through  
August 23**

## Marty Stuart's American Musical Odyssey

*Sparkle and Twang* tells the story of country music icon Marty Stuart's personal experiences with some of the most famous stars of American music, highlighting several of the greatest performers on the country, bluegrass, rockabilly, and Southern gospel scenes. This uniquely American collection underscores the importance of style and sound with performance costumes, handwritten lyrics, personal letters, musical instruments, and unpublished photographs of such legends as Patsy Cline, Hank Williams, Porter Wagoner, Johnny Cash, and Bob Dylan.



Country boys' late night, Studio A— Johnny Cash, Billy Sherrill, and Ray Charles, early 1980s. Photo by Marty Stuart.

### ADMISSION

\$9 for adults; \$5 for adults 60+ and students 13–18; \$3 for children 2–12; and free for veterans and children under 2.

4700 Western Heritage Way, Los Angeles, CA 90027 • 323.667.2000 • [AutryNationalCenter.org](http://AutryNationalCenter.org)

**FREE PARKING**



**[GREETINGS FROM TOM]  
New Water Line  
Construction**

**By L.A. City Councilmember  
Tom LaBonge**



The next time you drive through Griffith Park, you may notice construction work along Crystal Springs Drive. The trucks and crews will be there for the next couple of years because the Los Angeles Dept. of Water and Power is installing a new water line that replaces a major transmission pipe that is 70 years old and leaking.

This water line is being installed to improve water quality throughout the city. It will also address leaks in the existing line, which was installed in the 1940s, and increase water pressure for things like fighting fires in Griffith Park. There may be some traffic disruptions as the installation progresses, but in this case, the benefits far outweigh any inconvenience we may experience.

The project replaces a section of a water line that connects the North Hollywood Pump Station with the Ivanhoe Reservoir in Silver Lake. About 11,100 feet of 96-inch diameter welded steel pipe will be installed along Crystal Springs Drive from approximately 500 feet north of the intersection of Los Feliz Blvd. to the Los Angeles Zoo parking lot. Construction, which will last until about November, 2011, will include open trench and jacking and tunneling. The jacking and tunneling will be utilized to minimize the impact on traffic.

I hope you can be patient as this project unfolds. If you have specific issues or concerns, call my office and let me know: (213) 485-3337.

**[ERIC GARCETTI]  
Input Needed  
on Dog Park**

**By Eric Garcetti  
L.A. City Council President/  
CD13**



Our council district has approximately \$80,000 in Q U I M B Y funds—money paid by developers when they build projects in the area to help support neighborhood parks and open space—to make much needed improvements to the Silver Lake dog park area.

Together with the Dept. of Recreation and Parks and Bureau of Engineering, local residents and our council office, we have developed initial plans. As part of this process,

we met with the Silver Lake Dog Park Assoc. and the Silver Lake Small Dog Park Assoc.

City engineers have identified challenges involved with the dog park's site including its hillside location, which makes it difficult for water and waste to drain properly. We know that a full renovation of the dog park would need to include an upgrade to the irrigation system and the installation of catch basins for run-off. This would be a more expensive project, and it will take time to acquire the estimated \$1 million needed for a complete overhaul.

More immediately, however, we want to maximize the use of funding currently available to us for park improvements. The proposed plan is to expand the Small Dog Park to extend it to some of the unused land behind the recreation center. The city would also repair the

fences at both dog parks and add trees and bushes to the perimeter of the Silver Lake Dog Park to concentrate more activity in the middle of the area, which would help protect the health of the plants while giving the park a greener look and feel.

By the time the *Ledger* prints, we will also have input on the project from an April 25th community meeting. If you have additional comments, e-mail me at Councilmember.Garcetti@lacity.org.

**[PAUL KREKORIAN]  
Clean, Green  
Legislation**



**By Calif.  
Assem-  
blymember  
Paul  
Krekorian**

One of the benefits of living in Cali-

fornia is its forward-thinking ideas on the environment. Whether we trade in our plastic bags for reusable cloth sacks, bike to work, or use less water, it seems that everyone is doing all they can to conserve our natural resources.

As an Assemblymember, I have an opportunity to contribute to a strong and successful legacy of prescient environmental legislation. This year, I introduced new legislation that will precipitously ramp up our stock of clean energy. Assembly Bill 64 will help our state's electric utilities move from producing electricity using polluting fossil fuels that clog our air to generating clean, green power from renewable resources.

AB 64 would ensure that a third of our energy comes from renewable sources—like solar, wind and geo-

thermal—by 2020. The bill maintains our state's current goal of generating 20% of our electricity from renewable sources by 2010, establishes a second goal of 25% by 2015 and a third goal of 33% by 2020.

The benefits are clear and undeniable. Increasing our renewable energy is vital to reduce greenhouse gas emissions and slow global warming. The legislation will reduce our dependency on fossil fuels and stimulate sustainable economic development, including the creation of green jobs.

Assemblymember Paul Krekorian (D-Burbank) represents the cities of Burbank and Glendale, as well as the Los Angeles communities of Atwater Village, Los Feliz, North Hollywood, Silver Lake, Toluca Lake, Valley Glen, Valley Village and Van Nuys.

HEARING LOSS IS NOT REVERSIBLE BUT HEARING ABILITY CAN BE DRAMATICALLY IMPROVED !

Your parents always listened to you.

Do they need  
help hearing you now?

Your reward for being a good kid:

iPod® Shuffle™

Included with parent's purchase  
of a hearing aid

— EXPIRES 5/29/09 —



They fed you, clothed you, endured your soccer games and violin recitals, and always gave their best. Here's a chance to give your folks something back. If Mom or Dad has been working too hard to hear, encourage them to come in now for a comprehensive screening by our hearing health pros.



Even if your folks currently or previously wore hearing aids, the technology has advanced by leaps and bounds in recent years. Today's devices are more

powerful, more discreet & far more customizable than ever. We're working hard to make them more affordable, too. So do the right thing... call today to schedule their visit. You'll all feel good about taking the step.

Ask about our attractive financing options!

Now open on Saturdays  
and evenings by appointment.

Bring your parent(s) in for  
a precision hearing screening.

Call today to schedule an appointment:

LOS FELIZ 323.906.1036

Merrill Plaza • 2654 Griffith Park Blvd.

**HEAR** West  
LLC  
A HearUSA, Inc. Company  
www.hearusa.com

iPod and Shuffle are registered trademarks of Apple Inc. • Apple is not a participant in or sponsor of this promotion.



[DOG'S LIFE]

## Hear This: Ear Care for Dogs

By Jennifer Clark, Ledger Columnist

Ear maintenance, like teeth cleaning, requires weekly attention in order to properly protect one of dog's greatest assets; dogs have the incredible ability to hear four times better than their human counterparts.

While dogs with low hanging or floppy ears are most susceptible to ear infections, it's important that all dogs' ears be regularly checked and cleaned.

As with humans, dogs' earwax acts as a filter to catch bacteria and debris; it also works to snag foreign objects such as bugs and hair. Occasionally this wax can build up in the ear canal, creating a perfect environment for infection. If left untreated, ear infections can lead to a host of compli-

cations including damage to vital nerve structures and a change in equilibrium.

Signs of ear infection include incessant scratching at the site, head shaking and discharge. Should you observe any of these symptoms, immediately take your dog to the vet.

Weekly ear cleanings can help whisk away wax in order to avoid this kind of build up. Carefully lift the dog's earflap and apply an ear cleaning solution to the ear, then gently massage for about thirty seconds. The dog will shake away any excess solution and then you can use a soft cloth to remove any wax or debris that may arise.

While regular cleanings won't get your dog to listen to you any better, they will ensure healthy hygiene.

[RESTAURANT REVIEW]

## Yxta's Hidden Treasures

By Pat Saperstein, Ledger Restaurant Critic

Warn dinner companions that Yxta's location is in a rather barren, ominous area of downtown and it doesn't look like much from the outside.

Once inside, its interior seems completely unexpected, with sandblasted brick, high ceilings, evening light filtering through glass blocks, imaginative woven light fixtures and colorful original paintings.

Yxta Cocita Mexicana is the sister restaurant to Highland Park standby El Arco Iris, but with a more ambitious, updated menu of Mexico-city style specialties and a full bar with more than 20 tequilas. While the location seems remote in the dark of night, it's just a few blocks from Little Tokyo and an easy drive from other areas, with the bonus of ample free parking.

Arriving during happy hour, we quickly order excellent margaritas (\$5 at happy hour) and appetizers before the 7 p.m. deadline.

A basket of homemade-tasting tortilla chips arrive, with an intensely smoky salsa. It was rumored on Chowhound that its tacos al pastor were the best anywhere. That's a fairly lofty claim in this taco-blessed city, and they're indeed quite good. Chunks of meaty pork are coated in a chile sauce and folded into a homemade tortilla, and the taco is topped with a slice of pineapple for a nice interplay of sweet and spicy.

Entrees come with rice and beans, which are several notches above the usual combo fare. Chicken mole enchiladas in a deeply smoky poblano sauce had plenty of flavor and a simple arrachera steak with a mole cheese enchilada made a hearty entrée.

Entrée prices range from the vegetarian Calabacitas dish (\$12) with mixed vegetables over cilantro rice to Camarones al ajillo, sweet shrimp with garlic at \$22.

We finished with a rather dry chipotle chocolate cake and a much more successful rich, dense Kahlua flan, big enough to serve three or four people.

It's too bad that our inexperienced server made our meal less pleasant than it could have been, insisting on collecting the bill before we were ready to order dessert, and snatching dishes and drinks before they were done.

Considering how difficult it can be to find a Mexican restaurant that has both interesting, flavorful food and delicious, reasonably-priced margaritas, perhaps Yxta can encourage more welcoming service and become a lively downtown destination.

Yxta Cocina Mexicana,  
601 S. Central Ave.,  
213-596-5579

Pat Saperstein blogs  
about L.A. restaurants  
at EatingLA.com



[GOOD LIFE]

## Sippin' in the Summer

By Paul Hickey  
Ledger Wine and Spirits  
Columnist



As hot weather approaches its time to take a look at summer libations.

Wine coolers and spritzers make very refreshing summer drinks, and are easy on the budget and light on alcoholic content. Fill a tall highball glass with ice. Pour red wine to the halfway point and fill the rest with 7-Up or Sprite. For a spritzer use white wine and club soda with a lemon twist garnish.

Mojitos are increasingly growing in popularity. They are made by crushing mint leaves in the bottom of a double rocks glass and muddling with a teaspoon of sugar. Add two ounces of white rum, ice, and fill with club soda. Squeeze in half a lime and enjoy this great cocktail.

Still popular is the mai tai. This recipe is a surefire crowd pleaser and is a version of those served at Damons in Glendale: fill a glass with crushed ice and pour in one shot of white and one shot of dark rum. Add a shot each of pineapple and orange juice. Top off with a dash of curacao, a dash of orgeat and garnish with a pineapple chunk, maraschino cherry, and wedge of lime. The paper umbrella is optional!

# The Farmer's Cart



Fresh Organic Produce Home Delivery Service

How it works:

- Mother Nature will surprise you weekly or bi-weekly with a different produce ensemble from the freshest of her harvest!! Your box will contain 10-15 kinds of fruits and vegetables. These are grouped into 3 tasty general categories: Cooking Veggies, Salad Veggies and Sweet Fruits.



Here is an actual recent, delicious menu:

-5 Yellow Peaches	-3 Jumbo Artichokes
-6 Pluots	-16oz Green Beans
-5 Bananas	-1 Sno White Cauliflower
-16oz Strawberries	-4 Yellow Zucchini
-4lbs Valencia Oranges	-1 Bunch Spinach
-Crunchy Bean Sprouts	-4oz Spring Mix
-1 Bunch Carrots	-1 Pint Cherry Tomatoes

**\$39**

Delivered Price. Cash, checks or credit cards accepted. Ask about our smaller, \$29 box option.

-With The Farmer's Cart, you have no tedious weekly preference forms to complete. Save this time for your family or the beach. Only the freshest, highest quality produce will be hand selected for your box.

For more info or to subscribe, please visit us at [www.thefarmerscart.org](http://www.thefarmerscart.org). Or, call 213.509.9821.

 Preserve the Earth!  
© 2005 The Farmer's Cart.

# indochine

vien

vietnamese cuisine

Enjoy authentic Vietnamese comfort food in a hip space



Open 6 days a week  
Sun, Tue - Thurs 11:30am - 10pm  
Fri - Sat 11:30am - 11pm  
Monday Closed

Atwater Village  
3110 Glendale Blvd  
Los Angeles, CA 90039  
Tel: 323-667-9591  
[www.indochinevien.com](http://www.indochinevien.com)

ZAGAT RATED

"What a neighborhood bookstore should be..."  
*L.A. Times*

- Great selection of books about Los Angeles
- A full schedule of author events
- Unique greeting cards



**MARY ROACH**  
AUTHOR OF  
*Stiff*

"Bonk" by Mary Roach  
Now out in paperback from W. W. Norton

# SKYLIGHT Books

1818 N Vermont Ave  
(next to the Los Feliz Cinema)  
**323-660-1175**  
open daily 10am - 10pm

[www.skylightbooks.com](http://www.skylightbooks.com) order any book in print 24 hours a day

[EASTSIDE EYE]

**A New Home for Photography**

By Kathy A. McDonald, Ledger Columnist



“Los Angeles is my landscape,” photographer Catherine Opie told me

at a March preview of the Annenberg Space for Photography in Century City.

The former Silver Lake denizen is one of 11 photographers whose work is showcased in L8S AN-G3LES at the newly opened glass-walled exhibition space.

Backed by the Annenberg Foundation and philanthropist Wallis Annenberg, the 10,000 square foot gallery celebrates fine art photography and welcomes all for free. The inaugural show gives a selected survey of some of the city’s most talented and versatile photographers: from the Pulitzer prize-winning photojournalism of *The Los Angeles Times*’ Lawrence Ho to Lauren Greenfield’s documentary photo series “Thin.”

Famed architectural photographer Julius Shulman’s work greets visitors at the door to the circular space. Inside, digital screens and digital touch tables allow visitors to view even more images. Above, a sculpted, oversized camera lens frames the ceiling while the cushy flooring is made from recycled tires.

Opie has been photographing the city for more than 20 years; her observational style is represented with portraits from West Adams and a series of Polaroid pictures.

“Los Angeles is the center of still photography,” said photographer Douglas Kirkland.

Best known for his work on film sets, Kirkland shared that the secret to his revealing portraits is a personal connection with his subject. Both he and Greg Gorman have emblematic images of Andy Warhol; captured decades apart,



Photographer Doug Kirkland in front of his work at the Annenberg Space.

but displayed within steps, the contrast between the two photographers’ styles is sharply exposed.

A Thursday night lecture series—free but reservations required—workshops and weekday lunchtime digital exhibits are among ongoing planned events.

*Annenberg Space for Photography, Wed.-Sun. 11 a.m. - 6 p.m., 2000 Avenue of the Stars, Century City. www.annenbergpacefor-photography.org*

[EASTSIDE EYE]

**Pick for May**

Richard Neutra Architect: Sketches & Drawings. Opening May 3 at the Central Library’s Getty Gallery, building renderings, travel sketches and figure sketches by the famed architect recognized for the VDL Research House in Silver Lake and the Lovell Health House in Los Feliz. Free; gallery open during regular library hours. <http://www.lapl.org/events/neutra/>

[THEATER REVIEW]

**Silverlake Children’s Theater Rocks in May**

By Marilyn Oliver, Ledger Theater Critic



The Silverlake Children’s Theatre Group challenges children and teens with a contemporary repertoire. Since its 2001 founding, the group has presented productions with topics ranging from gender politics to greed, tolerance and the tyranny of the College Board.

“Our mission is to use the power of theater to develop critical thinking and self-confidence, as well as to engage the imagination,” said director Broderick Miller.

Miller is a screen-writer who offered to direct one play for free when the group was in its early stages. His interest in children’s theater was piqued after he took his young daughters to a bad

performance of a children’s play at a major local venue. He felt it was condescending.

“I said to myself if I ever ran a children’s theater group I would do smart plays which would be written from their point of view. I don’t believe in pandering to kids,” he said.

The group now produces two plays in the spring in local theaters. One production for ages 7 and up; the second, for kids up to 18.

This May the group will present two plays on alternating weekends at the Knightsbridge Theatre in Silver Lake. The younger kids will stage “Significant Others,” a comedy musical set at the G8 Summit written by actor-comedian Mark McCrack-

en. The plot revolves around the wives of the delegates. Unhappy with the way their husbands are handling things, they take matters into their own hands. Friday & Saturday May 1st and 2nd, 7 p.m.; Sunday, May 3rd, 2 p.m.

The older actors will perform in a play called “The Rogues” written by Miller. The central figure is a girl who gets involved with a group of ‘70s rockers who are planning a one-time reunion. May 15th, 16th, 22nd, 23rd at 7 p.m.; May 17th and 24th at 2 p.m.

*Tickets, \$15 adults; \$10 for kids under 12. Reservations: (323) 216-6363. The Knightsbridge Theater, 1944 Riverside Dr.*

LAST LION PRODUCTIONS PRESENTS THE WORLD PREMIERE OF:

**DEAD, THEREFORE I AM**  
A GOTH-PUNK COMEDY BY MAX LEAVITT

EAST THEATRE @ THE COMPLEX  
6476 SANTA MONICA BLVD.  
HOLLYWOOD, CA. 90038

APRIL 17- MAY 24  
FRIDAYS & SATURDAYS @ 8PM • SUNDAYS @ 3PM

TIXS & INFO:  
[WWW.PLAYS411.COM/DEAD](http://WWW.PLAYS411.COM/DEAD)  
(323) 960-7714  
Mention code 007 for \$5 discount

“Hilariously grim tour de farce!” - *wehonews.com*  
“Four excellent actors.” - *ReviewPlays.com*  
“Intense and visceral...surges with emotion.” - *The Toluca Times*  
“The writing is elegant...poetic.” - *Socal.com*

**Come... what are you waiting for?**

- Beautiful Indoor/Outdoor café
- Sumptuous Organic baked goods
- Savory salads & sandwiches
- Exceptional coffee & tea
- Free WI-FI

Bring this ad in for a **FREE cup of coffee!**  
**Good thru 5/31/09.**

at the newly opened  
**LYRIC CAFE**  
at the Hyperion Theatre

2106 Hyperion Avenue  
in Silver Lake  
(323) 906-8904

Visit us at our New Location!  
Same great food, Same friendly service

**CHI DYNASTY**  
Since 1983

“Most unique and exotic Chinese cuisine for the gourmet”  
Serving Los Feliz for 21 years  
Family owned and operated

**Lunch-Dinner-Cocktails-Food to Go We Now Deliver!**

11:30am-11:00pm Sun-Thur  
11:30am-12:00 Midnight Fri-Sat

1813 Hillhurst Avenue  
Los Angeles, CA 90027  
(323) 667-3388  
[www.chidynasty.com](http://www.chidynasty.com)

[ MAY 2009 EVENTS CALENDAR ]

Art

**"Sketches and Drawings,"** exhibition features works by Los Angeles Architect, Richard Neutra, May 3rd through Sept. 6th  
Richard J. Riordan Central Library  
Getty Gallery, 2nd Floor  
630 W. Fifth St  
Reservations: (213) 228-7500  
www.libfnd@lapl.org

**"These Are Strange Times My Dear,"** a joint exhibition by Catia Chien, Dany Paragouteva, and CJ Metzger. This group show features the artist's interpretations of our current socio-economic and political instability. Artist Reception: May 9th, 7:00 p.m. to 10:00 p.m.  
May 9th through June 6th  
Black Maria Gallery  
3137 Glendale Blvd. (323) 660-9393  
www.blackmariagallery.com

**"Sparkle and Twang: Marty Stuart's American Musical Odyssey,"** an interactive exhibition features country music icon, Marty Stuart who shares his experience performing with legendary musicians, Elvis Presley and Johnny Cash. Through Aug. 23rd  
Autry National Center  
4700 Western Heritage Way  
(323) 667-2000  
www.autrynationalcenter.org

Books

**Smile Southern California, You're the Center of the Universe: The Economy and People of a Global Region,** by New York Times columnist, James Flanigan and Global California: Rising to the Cosmopolitan Challenge, by USC Professor of International Relations, Abe Lowenthal. Author Discussion and Book Signing: May 9th, 5:00 p.m.  
Skylight Books  
1818 N. Vermont Ave. (323) 660-1175  
www.skylightbooks.com

**Mustang, The Saga of the Wild Horse in the American West,** based on a true story by Deanne Stillman. Author Discussion and Book Signing: May 17th, 2:00 p.m. to 3:30 p.m.  
Free with museum admission  
Autry National Center  
4700 Western Heritage Way  
(323) 667-2000  
www.autrynationalcenter.org

**Friends of the Los Feliz Library Monthly Used Book Sale**  
May 23rd, 10:00 a.m. to 4:00 p.m.  
Los Feliz Library  
1874 Hillhurst Ave. (323) 913-4710

Children

**The Children's Nature Institute Family Picnic**  
Explore the great outdoors and enjoy a concert in the park.  
Free Admission

May 17th, 12:00 p.m. to 7:00 p.m.  
Old Picnic Area in Griffith Park  
4730 Crystal Springs Dr.  
www.laparks.org/dos/parks/griffithPK/calendar/calendar.htm

**Elmo's Green Thumb**  
Live On Stage Performances with Sesame Street characters: May 29th, May 30th  
Nokia L.A. Live Theatre  
777 Chick Hearn Court  
www.ticketmaster.com

Clubs

**Los Angeles Breakfast Club**  
Wednesdays, 7:00 a.m. to 9:00 a.m.  
Friendship Auditorium, 3201 Riverside Dr., Public welcome.

**Silver Lake MOMS Club Annual Rummage Sale**  
Clothing and other items for adults and children. Baked goods and drinks also available.  
May 17th, 9:00 a.m. to 2:p.m.  
2580 Armstrong Ave.

**Atwater Village Library Book Club**  
May 12th, 1:00 p.m.  
3379 Glendale Blvd.  
(323) 664-1353

**Echo Park Crochet & Knitting Club**  
Beginners welcome  
May 9th, 23rd, 11:00 a.m.  
1410 W. Temple St. (213) 250-7808

**Los Feliz Library Chess Club**  
All ages and levels are welcome.  
May 2nd, 2:00 p.m.  
1874 Hillhurst Ave. (323) 913-4710

**Los Feliz Library Scrabble Club**  
All are welcome. Bring your own boards.  
May 9th, 1:00 p.m.  
1874 Hillhurst Ave. (323) 913-4710

Dance

Dance Downtown Series:  
**Mexican Cumbia,** May 15th  
Texas Two-Step & Line Dancing,  
May 29th  
Beginner lessons begin at 6:30 p.m.  
Free Admission  
Music Center  
135 N. Grand Ave. (213) 972-3660  
www.musiccenter.org

Los Angeles Ballet Presents:  
**La Sylphide,** a romantic ballet with storytelling of love, betrayal, death, and magic.  
May 30th, 7:30 p.m.  
Alex Theatre  
216 N. Brand Blvd. (818) 243-2539  
www.alextheatre.org

Fashion

**Friends of the Autry Fundraiser Fashion Show and Luncheon,** includes a silent auction, raffle, lunch, and Western wear by Scully.  
May 4th, 11:00 a.m. to 2:00 p.m.

4700 Western Heritage Way  
(323) 667-2000  
www.autrynationalcenter.org

Food

**Celebration of Life, A Night in San Miguel de Allende**  
Cinco de Mayo Celebration: A Para Los Ninos Benefit  
Enjoy delicious Mexican cuisine, dancing, mariachi music, live and silent auction.  
May 1st, 6:30 p.m. to midnight  
Gilmore Adobe  
6301 W. Third St.  
Tickets & Information:  
(213) 250-4800 #529  
www.paralosninos.org

**Armenian Independence Festival**  
Live entertainment, Armenian dances, food and a kids zone.  
May 24th, 11:00 a.m. to 7:00 p.m.  
Hollywood Blvd. between Alexandria Ave. and Vermont Ave.  
(818) 243-9264  
www.littlearmeniafestival.com

Politics

**Silver Lake Neighborhood Council**  
May 6th, 7:00 p.m.  
1511 Micheltorena St.  
Micheltorena Street Elementary School  
www.SilverLakeNC.org  
**Greater Griffith Park Neighborhood Council**  
May 19th, 7:00 p.m.  
Los Feliz Community Police Center  
1965 Hillhurst Ave., 2nd floor  
www.ggpnc.or

Music

**Los Angeles County Museum of Art Friday Night Jazz Series:**  
Bruce Lofgren Trio, May 1st,  
Jon Mayer Trio, May 8th,  
Steve Lockwood Trio, May 22nd, and  
Meth-Four West featuring  
Eric Person, Dwight Trible, May 29th  
6:00 to 8:00 p.m.  
Free Admission  
LACMA  
LA Times Central Court  
5905 Wilshire Blvd. (323) 857-6115  
www.lacma.org

**The Greek Theatre Spring Concert Series:**  
L.A. Latin Jazz Festival: Caribbean Jazz Project, May 16th, 7:00 p.m.  
The Allman Brothers Band & The Doobie Brothers, May 19th, 7:00 p.m.

War, Tierra, Malo, May 23rd, 6:30 p.m.  
Flight of the Concorde with special guests Arj Barker, May 24th, 8:00 p.m.  
The Greek Theatre  
2700 N. Vermont Ave.  
www.ticketmaster.com

Lectures & Learning

**Free Computer Classes for Seniors**  
Learn how to navigate through the Internet.  
May 5th, 3:00 p.m.  
Los Feliz Library  
1874 Hillhurst Ave. (323) 913-4710

Veteran journalist, **Robert Scheer,** will discuss and argue how America's defense policy in Iraq is ineffective in winning the war against terrorism. Free Admission. May 21st, 7:00 p.m.  
Glendale Public Library Auditorium  
222 E. Harvard St.  
(818) 548-2042

Los Angeles Astronomical Society and  
**the Los Angeles Sidewalk**

**Astronomers** look at celestial bodies using a variety of telescopes and meet with amateur astronomers. May 2nd, 30th 2:00 p.m. to 9:45 p.m.  
Griffith Observatory, 2800 East Observatory Rd. (213) 473-0800 or  
www.griffithobservatory.org

Theatre

**Drama West** performs live readings with new scripts  
May 16th, 2:00 p.m.  
Edendale Library  
2011 W. Sunset Blvd. (213) 207-3000

National Endowment For The Arts Presents:  
**The Taming of the Shrew,** by William Shakespeare, directed by Geoff Elliott.  
Live On Stage Performances:  
Through May 17th  
A Noise Within  
234 S. Brand Blvd. (818) 240-0910 Ext#1  
www.anoisewithin.org

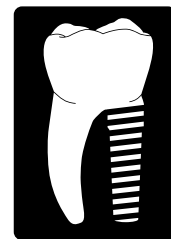

**Dr. Saeghi & Associates**

WHERE SCIENCE IS COMMITTED TO ART  
A PROFESSIONAL DENTAL CORPORATION

**Ali Saeghi, D.D.S.**  
Implant, Cosmetic & General

Please inquire about our specials  
new patients only

3151 Glendale Boulevard  
Los Angeles, CA 90039  
TEL: 323.660.1205  
FAX: 323.660.1214

Serving in 3 locations: Los Angeles • Ojai • West Hills



jonmeasures.com

*Expand Your Mind by a Degree*

MOUNT ST. MARY'S COLLEGE  
M.A. in HUMANITIES

Designed for working professionals and offered entirely on weekends, our Humanities program focuses on English, history, creative writing, and cultural studies.

For more information visit  
www.msmc.la.edu/HUM2  
or call (213) 477-2800.

10 Chester Place • Los Angeles 90007



**[FAMILY MATTERS]**  
**Aw, Geez, Mom, Cut it Out!**  
 By Kristen Taylor, Ledger Columnist

Uh oh. I've become that parent. You know the one: I'm the mother who babies her growing children to the point of eye rolling and groaning; to the point where I'm embarrassing not only my kids, but myself as well.

When our children are babies, we have the luxury of observing people with their older kids, and swearing that we'll never commit the same

napkin to his face and started wiping away.

"Mom, once again, don't just come at me with a napkin. It's overwhelming."

If your kid talks like a thirty-five year old, he's probably old enough to wipe his own face.

My daughter has been the victim of similar attacks, but even worse, they were committed with a spit-swabbed finger.

struggle and inner dialogue that goes back and forth between, "Back off and let them handle it," to, "Just get it done." Sometimes it's more efficient to do things yourself, rather than explain something patiently and supervise the process. And sometimes I don't want to clean up the mess that will result in the kids doing things for themselves, or go through the three tries it might take. But obviously, there are times when I step over the line to complete dork, and that is when the kids have clearly grown up enough

to handle certain things themselves.

So I pledge right now that I am not going to be that mother, the one who sits next to her son at his wedding and cuts

his steak for him. Or maybe I'll just insist that he have the chicken. He likes it better, and there's so much less fat.

Happy mother's day, to all you mom's out there.

**My daughter has been the victim of similar attacks, but even worse, they were committed with a spit-swabbed finger. "Mom, don't wipe your spit on me! That's gross!"**

goofy mistakes that are so easy to observe in others. It turns out that those infractions almost impossible to avoid.

Last week, the kids and I were out to lunch, and while we were talking I noticed a whole lot of ketchup on my son's face. Without announcing my intentions or even thinking about it, I took my

"Mom, don't wipe your spit on me! That's gross!"

Yes, indeed it is. But how do I help it? We spend the early years fulfilling our children's every need, often before they even realize those needs themselves. Those patterns and habits are tough to break.

Being a parent to a growing child makes for a constant

Custom Design & Installation of Solar Energy Systems

www.CalSolarEnergy.com

California Solar Energy™  
 "Experts in the Recycling of Mother Nature"

Robert Romanin  
 818.219.2606

323.478.0330  
 CA Licensed Solar Contractor  
 No. C46-860813

**Special Introductory Price  
 Three Private Sessions  
 Only \$165**

**PILATES METRO**

leaner, longer, firmer, stronger

gift certificates available

**323.906.0088**  
 www.pilates-metro.com  
 3178 Glendale Blvd. LA, CA 90039

www.silverlakehealthwellness.com

Silver Lake Health and Wellness Association

One Body, Spirit, Mind

THE ASSOCIATION IS A MULTIDISCIPLINARY ORGANIZATION OF INDEPENDENT PRACTITIONERS FOR BODY, MIND AND SPIRIT COMMITTED TO THE PROMOTION OF PHYSICAL, EMOTIONAL AND SPIRITUAL WELLNESS AND TO PROVIDE QUALITY CARE FOR THE COMMUNITY. EACH MEMBER IS SOLELY RESPONSIBLE FOR ALL GOODS AND SERVICES THEY PROVIDE.

FOR INFORMATION, CONTACT WANDA JEWELL, LCSW, (323) 664-1846.

A TIME FOR HEALING.  
 A TIME FOR HOPE.

Wanda Jewell, PhD, LCSW  
 Dynamic Psychotherapy  
 (323) 664-1846  
 Exceptional Therapy for Exceptional Times

KATHRYN PALLAKOFF  
 ADVANCED BODYWORK

- Rolf Structural Integration
- CranioSacral Therapy
- Meridian Sound Healing
- Chi Nei Tsang/ Visceral
- Energy Medicine

323-363-1770  
 SACREDKNOTS.com

before after

Gee, I could really use a therapist.

**jl** Jessica LeRoy MA, MFT

SPECIALIZING IN THE PSYCHOLOGY OF WOMEN

learn more at [www.jessicaleroy.com/ledger](http://www.jessicaleroy.com/ledger)  
[jleroy@jessicaleroy.com](mailto:jleroy@jessicaleroy.com) 323.369.0755

Marriage & Family Therapist, License #MFC44907  
 Illustration courtesy of [www.alysonfox.com](http://www.alysonfox.com)

**Now Healing**

Chinese Energetics for Body Mind Spirit  
 Private Sessions, Workshops. Elma Mayer, MA  
[www.nowhealing.com](http://www.nowhealing.com) (323) 309-7687

SILVER LAKE HEALTH and Professional center  
 Health care is for people not profit

- CHIROPRACTIC  
 Dr. Cheryl Revkin, D.C. 323.665.1281
- HOLISTIC NUTRITION  
 Izabela Kelly, HHC, AADP 213.483.2824
- acupuncture  
 Irina Tsoy, L.Ac., Dipl. Ac. 323.683.5969

1724 W SILVER LAKE DRIVE, LA 90026  
 1751 SILVER LAKE BLVD, LA 90026  
 www.silverlakechiro.com

**The White Lotus**

1924 Hillhurst Avenue, LA, CA 90027  
 323-665-7322

Gifts · Books · Apothecary · Workshops · Readings  
[www.TheWhiteLotusInc.com](http://www.TheWhiteLotusInc.com)

Joan Kim-Wagner, M. Sc, L.Ac.

Joan Kim-Wagner is a third generation, experienced practitioner of acupuncture and oriental medicine who is committed to empowering patients to maintain optimal health and vital energy.

1501 Colorado Blvd. Evergreen Wellness Center  
 Eagle Rock, CA 90041 323.244.1985  
 (corner of Loleta) Most insurance accepted

Silverlake Acupuncture  
**Michael L. Fox, L.Ac.**  
 Diplomate in Oriental Medicine

323. 662. 6560

2114 Hyperion Ave.  
 Los Angeles CA 90027  
[www.SilverlakeAcupuncture.com](http://www.SilverlakeAcupuncture.com)

**Elaine Silberman, Ph.D., Psy.D**  
 Licensed Clinical Psychologist, # Psy13381

Contemporary Relational Psychoanalyst  
 323-664-8240, Silver Lake

Specializing in: depression, anxiety, assertiveness, shyness, relationships, couple communication, eating problems, self esteem issues and parenting.

**Paula L. Capps M.S., L.Ac, Nat. Dipl. OM**  
 Licensed Acupuncturist  
 Fertility Specialist  
 Intuitive

paulalc@me.com  
[www.handmadeuniverse.com](http://www.handmadeuniverse.com)  
[www.paulacapps.com](http://www.paulacapps.com)

310-750-5669

[ OPEN MIKE ]

## GGPNC: Appointed Members Ensure Board Diversity

By Philip Gasteier

Regarding, "GGPNC: Appointed Members Breed Cronyism," by Tomas O'Grady (*Los Feliz Ledger*, April 2009) neighborhood councils are an experiment in progress. Prior to Greater Griffith Park Neighborhood Council certification in 2002, stakeholders active in the Los Feliz/Franklin Hills area spent several years developing a structure which would reflect its rich traditions of diversity, tolerance and creativity, but also function to serve the community.

The GGPNC has an established tradition of civility and community service. Recently some comments have appeared in the *Ledger* which I fear threaten this tradition and do not accurately reflect the facts.

I invite you to participate in the real world of GGPNC activists working for the community which they love. Our board is committed to openness, inclusion and service.

The GGPNC is an advisory body of the city of Los Angeles. NCs' primary purpose is providing city government information to stakeholders and assisting them in having their views heard by the city. We receive limited funding for operations, outreach and community improvement, but members are all unpaid volunteers. We can't tax you. We do not pass laws. In short, the GGPNC is primarily a service organization, to help stakeholders use city government.

Space does not allow listing matters in which the GGPNC

has recently played a leading role. Rest assured that these matters involved dedicated volunteer service of board members, some appointed members whose terms are to end in August 2009. The assertion that appointed members are the result of "cronyism" does a huge injustice to those members and ignores crucial facts.

The GGPNC's structure contemplated appointment of some board members based on input from community groups, seeking broad representation, and inclusion of skills to help the GGPNC carry out its mission. This recognized the legal duty of NC's to promote diversity and represent all stakeholders. It has enabled the GGPNC to find wonderful committee chairs, fill difficult jobs such as treasurer or secretary, add members of unrepresented groups, and engage community leaders. It is still evolving. Bylaws were revised in 2007 to allow time after elections to solicit community input.

This year we have procedures to further open up the process. Selection is scheduled for a meeting this August, when the community can hear presentations and express their views. Any stakeholder may apply. By law, stakeholder voting elections are run by the City Clerk and can not happen until 2010.

No board structure is perfect. Many other NC's have seats elected only by specific groups, unlike any legislative elections. All stakeholders can vote for all 10 elective seats on the GGPNC. Did you know that only one appointed member has been on the board from the beginning? That each time appointments have been made, only two of 9 were reappointed? That many appoint-

tees were previously unknown, or known only by their prior community involvement?

NC's remain a great experiment. This is Los Feliz. Whatever your opinion on the proper structure for these advisory bodies, let's work to retain our traditions of openness to new ideas and listening to our neighbors without judging them based on preconceptions.

*Philip Gasteier has been the president of the GGPNC since August 2008.*

## Appointments Are Democratic

By Tal Vigderson

Regarding "GGPNC: Appointed Board Members Breed Cronyism," by Tomas O'Grady, (*Los Feliz Ledger*, April 2009), I read with great interest the editorial by my fellow board member, Tomas O'Grady in last month's edition.

I'd like to impart a little background based on my three years of experience on the council, if I may.

It's worthy to note all positions on the GGPNC, whether elected or appointed, are volunteer positions. As such, each member—with few exceptions—is part of the council as a result of a desire to make our neighborhood the best that it can be. Rarely have I seen a member make a comment or vote based on a personal agenda.

I ran for a seat on the council in my district and lost by a few votes. I received more votes than some of the winners in other districts. I was encouraged to apply for one of the appointed positions by members of the council and my community. My appointment was considered first by the executive committee and then in a general meeting where the public was encouraged to attend and make comments. Several comments were made and a vigorous

debate ensued. After all the facts were carefully weighed, I was voted on to the council. I hope that I have been worthy of my appointment.

But at no point did I feel I was benefiting from cronyism. I didn't, prior to the election, know any members of the board. I certainly didn't have the opportunity or ability to lobby any of them for my seat. I was chosen, as were the other appointed members, based on my credentials and my candidate statement. The advantage of having some elected positions and some appointed positions—especially now that our elections follow the citywide course (i.e., once every two years)—is that it allows us to have an incumbent group in place at all times. If we were to elect the entire slate at once we run the risk of having an entire freshman class with no experience and no history. I have learned a tremendous amount from working with Phillip Gasteier (our current president), Charlie Mimms (our former president), Kurt Rademaekers and many of the other "old guard" members. I have found them to be a very fair minded and dedicated bunch who want nothing more than the best for our community.

Allowing a democratically elected board to select, with public comment, additional appointed members does not vitiate the principles of democracy. Appointed positions are a mainstay of our government. For example, all federal judges are appointed, as are all cabinet positions.

In addition, having appointed members gives the board the opportunity to include members that may not have the time or inclination to run in the election. While some may see that as cronyism, I believe it gives us the best of both worlds. We elect the majority of our members and then we give opportunities to others that have a desire to serve. Indirectly the people are being chosen democratically by

elected members. And, as noted above, members of the community have an additional opportunity to voice their opinions at the time the appointed members are chosen.

I urge anyone who feels there is an abuse of democracy at the GGPNC to attend our next meeting. I think they will find that the spirit of democracy is alive and well on the council and that although the potential for abuse may exist actual abuse does not exist on the GGPNC.

*Tal Vigderson is an appointed board member of the Greater Griffith Park Neighborhood Council.*

## The Need for Appointments Has Passed

By Ricardo Gomez

Regarding "GGPNC" Appointed Members Breed Cronyism," by Tomas O'Grady, (*Los Feliz Ledger*, April 2009), I am the first member of the steering committee that created the GGPNC.

Creating the GGPNC was a long, arduous process. Some wanted an all elected board. Another group—myself included—wanted an all appointed board. People like me, who had a long history of neighborhood volunteerism, were fearful that neophytes would get elected and wreak havoc. So, we thought existing community groups should appoint neighborhood council board members.

Nearing our city deadline for our application, I came up with a compromise.

I drew up elected districts so that the initial majority was elected. That elected board would then appoint other board members. Again, we thought doing so would ensure a diverse board of experienced people. Our premise was that the electoral process

*see Gomez page 25*



**ATWATER VILLAGE FARMERS' MARKET**  
A CERTIFIED FARMERS' MARKET

**Fresh produce direct from the farmer to you!!!**

**10:00 a.m. - 2:00 p.m.**  
Every Sunday Rain or Shine  
3250 Glendale Blvd.  
(Glendale at Larga Ave.)  
Wells Fargo Bank Parking Lot,



## Earn up to \$800 a month Hosting Japanese Students

Students prefer to live with a family; students require their own room; some meals should be provided.

For all details please contact Kelly at Language Systems:  
**213-385-2365** from 1:30pm to 6pm, M-F  
or [kelly@languagesystems.com](mailto:kelly@languagesystems.com)

[ OPEN MIKE ]

*Gomez from page 24*

could not be trusted to achieve these goals.

But after the first GGPNC election in the early 2000s, the selection of appointed board members was fraught with allegations of fraud, vote trading and favoritism. I have no direct knowledge of the facts but the overall community perception was that the process appeared improper. The stigma surrounding the appointment of GGPNC board members persists today. There is a community perception of "an appearance of impropriety."

Today is a new age. I strongly believe the GGPNC should allow stakeholders to elect all board members. There is no need for appointments. Our fears were false.

The electoral process can be trusted to deliver dedicated community servants. If no one runs for an elected position, the board can then appoint someone to fill the position until the next election.

Neighborhood councils are about achieving transparency in government. Direct elections are the way to achieve this.

*Ricardo Gomez is a resident of Franklin Hills.*

## Crosswalk a Benefit?

By Dion Neutra

I just read in the *Los Feliz Ledger* that the NIMBY forces have evidently derailed Eric [Garcetti] to where he is again seriously considering disrupting the flow of normal traffic by the installation of a pedestrian only crossing in the 2300 block [of Silver Lake Blvd].

I can't believe that the [Dept. of Transportation] would be party to such an insane scheme, which has the potential of disrupting the necessary flow of traffic on this major artery which serves as a bypass for the failed 2 Freeway extension to the Northwest. At peak traffic hours, this could be devastating!

By contrast, at Earl St., by facilitating traffic flow and solving the Earl St. transitions, there is the possibility of metering the major traffic flow by synchronizing the flow with Duane St. at least, and timing pedestrian desires such that it has the least disruptive effect on the major traffic flow; no?

*Dion Neutra, architect AIA, FISD  
Dion Neutra, Inc.  
Silver Lake*

## Relay for Life 2009: Walking in Circles And Really Getting Somewhere

By Jody Cherry

On June 6th if you are driving or walking by the Mulholland Fountain at the corner of Los Feliz and Riverside you will see something different. Next to the photographers with their wedding and quinceniara subjects will be many people walking in circles, and it will be one of those rare moments when people walking in circles will actually get somewhere. What you will see is the Relay For Life of the Griffith Park communities, Atwater Village, Franklin Hills, Los Feliz, and Silver Lake, a 24 hour event raising funds to support the research and community support work of the American Cancer Society. Planned and realized by volunteers—your friends and neighbors—the 2009 Relay will be the area's second annual.

During the 2008 Relay For Life, 13 teams walked the track at Marshall High School representing each of the elements of Relay's CEL-

EBRATE – REMEMBER – FIGHT BACK motto.

Pinky's Team Silver Lake was captained by area realtor and breast cancer survivor Caroline "Pinky" Luat Young. Pinky was moved by the friends who joined her team to celebrate her and others they knew touched by cancer and mostly her husband Kent.

He is, she said, "my soulmate [and walked] in celebration of my life for hours at my side."

Tracy DeSanctis of the Los Feliz Citibank branch started her team, The Golden Dreams Team, to remember colleague and friend Cyndi Golden who lost her fight to pancreatic cancer in Oct. 2007.

"She was such a dynamic lady that touched so many of our lives at work and outside of work. I felt so helpless and wanted to do something for her family and friends in her memory."

Fight Back is something each team is doing with their participation, but was most exemplified by Susie's Army. Captain Ileana Lopez's team consisted of 11 kids and seven adults all walking for her sister-in-law Susie whose Non-Hodgkins Lymphoma is currently "asleep." Ileana said that

for the children "the Relay was very symbolic, they really wanted to show their aunt how much she means to them."

The Relay For Life starts at 8 a.m. with the Opening Ceremony and the Survivor Lap. Come by and cheer on your neighbors and celebrate their lives in the face of cancer.

The Luminaria Ceremony at 9 p.m. is another opportunity to celebrate survivors' lives and a chance remember those who have lost their battle. The luminaria that will ring and light the track for the night are being decorated by area elementary school students.

The Closing Ceremony at 8 a.m., June 7th is the time to learn the event results and hear Relay participants' pledges to continue to fight back against cancer. Anyone can attend any of the ceremonies, form a team or join in the planning of the event visit [www.relayforlife.org/griffithparkca](http://www.relayforlife.org/griffithparkca) for more info.

*Editor's Note: The Los Feliz Ledger will have a luminaire candle at the Relay for Life, for our dear friend and Wine and Spirits columnist Chris Rubin, who died of cancer Aug. 15, 2008.*

*Jody Cherry is a member of the planning committee for this year's Relay for Life.*

# Red Lilly

## PLUMBING HEATING SEWER & DRAIN SERVICE

• SINCE 1924 •

**24/7 • 365 days a year**

Call now for FREE estimate

**FREE camera inspection  
with any roter service**

Locate roots, collapsed pipe's and view problem drains  
Video recording and locating at additional cost

**NOW INSTALLING TANKLESS WATER HEATERS**

Earth friendly/cost effective Ask about \$200 rebate

Discount code #LF/LED Lic. # C218270

**323 664-2906**

Sewer & Drain Cleaning  
Pipe Repair & Replacement  
High Pressure Water Drain Cleaning  
Copper Repiping  
Root & Sludge Removal

We Repair, Service and Install...

- Water Heaters
- Sinks and Toilets
- Heating and A/C
- Water, Gas & Slab Leaks
- Pressure Regulators
- Garbage Disposals
- Lawn Sprinklers
- and More



[www.redlillyplumbing.net](http://www.redlillyplumbing.net)



[RELIGION AND SPIRITUALITY]

## A Torah Donated, A Life Remembered

by Roberta Morris, Ledger Religion Columnist

**LOS FELIZ—** On Jan. 31st, Knesset Israel in Los Feliz celebrated the presentation of a new Torah donated by Ben and Effie Raber. The donation is even more meaningful today as Ben passed away on March 19th.

The Torah was donated in honor of the couple's 70th wedding anniversary.

"It's was just like a wedding," said daughter Miriam Fishman. "When we all walked down the isle it was really moving. There were four generations, quite a few great grandchildren, at least five."

The Rabers have been members of the synagogue for over 50 years. Ben served as its president. And Effie was in charge of the Hadassah Chapter.

Torahs can cost between \$25,000 and \$60,000. They are written by hand—with an old fashioned quill—a process that can take up to a year. Then the text is put through a scanner to check for errors. The Rabers Torah had one small error that synagogue officials said was easy to fix.

The Rabers first immigrated to Canada from Russia and moved to the U.S. in 1956.

Other organizations that have benefited from the Raber's generosity include the United Jewish Association,

Israel Bonds, Bar Ilan University, Hebrew University, the American Heart Association, Parkinson's Foundation, The Arthritis Foundation, The



Rabbi Robert Elias and Ben and Effie Rabner with the donated Torah [foreground].

American Cancer Association, United Negro College Fund, St. Jude's Hospital, the American Indian Association and many more.

Their children take pride in their parent's tradition of giving.

"Ben and Effie Raber considered it a privilege to get requests for donations and never turned anyone down," said Miriam.

According to Miriam, the

Torah dedication ceremony was held off until the end of January because of her father's poor health.

"He'd never retired," said

Miriam, "but he stopped working in November because of his health. [The ceremony] was the first time he allowed us to push him in a wheel chair. He was very determined."

Custom goes that people who buy and donate a Torah can fill in the last few words. Because the Raber family is so large, Miriam said, the scribe left the last lines free, instead.

"My dad filled in the last words," she said, "and the rabbi said despite his failing health his hand was very steady."



[STAR GAZING]

## May 2009

By Anthony Cook, Griffith Observatory

Saturn is best seen during the evening twilight. It is the bright gold-hued "star" appearing two-thirds the way between the southern horizon and the overhead point. It is to the lower left of Leo the Lion's bright star, Regulus. Telescope owners will want to watch the rare passages of the inky shadow of Saturn's largest moon, Titan, across the face of the planet. These will start at 10:27 p.m., P.D.T. on the 13th, and at 9:33 p.m. on the 30th. Saturn sets in the west before 3:00 a.m.

When dawn starts, Venus and Jupiter are easy to see and can help point the way to fainter planets. Venus is the brightest planet—the third brightest celestial object after

the sun and moon. It is eye catching and low in the east as the sky brightens. At the same time, Jupiter is somewhat fainter, and has a cream-yellow hue, and is to the upper-right of Venus above the southeast horizon. Rust colored Mars is the bright rust-colored "star" located about six degrees (1 binocular field-of-view) to the lower left of Venus.

The moon appears at first-quarter phase on the evening of the 1st, reaches full phase on the night of the 8th, is at last quarter on the morning of the 17th, is new on the morning of the 24th, and is first-quarter again on the evening of the 30th. It passes close to Saturn on the 3rd and 30th, near Jupiter on the 24th, and near Venus on the 20th and 21st.

### Volunteers Needed for Big Sunday, May 3rd

On Sun., May 3rd, starting at 9 a.m., Farm Feliz in partnership with Big Sunday will conduct joint beautification and spring cleaning at Thomas Starr King Middle School.

Work planned includes planting the new learning and sensory garden, painting murals and the Fountain Ave. breezeway. There will also be a "recycled fashion" store, a book exchange, a children's play/safe space, a health and wellness fair, community outreach booths, a live band and food created by Large Marge Sustainables

[www.largemargesustainables.com](http://www.largemargesustainables.com)

Now in its 10th anniversary, Big Sunday is the largest community service event in the United States. This year, an anticipated 50,000 volunteers will fan out across Southern California volunteering at over 300 non profits, schools and other agencies.

For info: contact Dana Cremin at [danajoy@creminfamily.com](mailto:danajoy@creminfamily.com), or visit: [www.bigsunday.org](http://www.bigsunday.org). To volunteer for the King Middle School Project visit: <http://bigsunday.org/project/180>.

**★ TEMPLE KNESSET ISRAEL ★**  
 "Your Friendly Neighborhood Shul"  
 Join us for Shabbat services at 9:15am every Saturday followed by bagels, some sweets and a lively Torah discussion.

- 2 blocks South of Sunset Blvd.
- Se Habla Espanol
- A conservative congregation
- All are welcome!
- Free and easy parking

1260 North Vermont Ave, Los Angeles, CA 90029  
 323-665-5171 | [www.templeki.org](http://www.templeki.org)

**First Presbyterian Church of Hollywood**

**Sunday Worship**  
 Contemplative Service, 8:30 am, Wylie Chapel  
 Traditional Service, 9:30 am, Sanctuary  
 Worship at 11 am, Sanctuary

**Wednesday Bible Study**  
 6:45 pm  
 Mears Center  
 Led by Dr. Gary Stratman

**The Filling Station**

1760 N. Gower St., Hollywood, CA 90028  
 463-7161 [www.hollywoodpres.org](http://www.hollywoodpres.org)

**Something Good is Happening at First Church – Join Us!**

**TRADITIONAL WORSHIP SERVICE**  
**SUNDAY MORNINGS AT 11:00A**  
 Be uplifted by Dr Colglazier's inspirational sermons:  
 May 3 – *Luggage vs. Baggage?*  
 May 10 – *Don't Give Up on Yourself!*  
 May 17 – *Have You Ever Been Afraid?*  
 May 24 – *Do You Need a New Beginning?*  
 May 31 – *Let the Spirit In!*

**ENRICHMENT OPPORTUNITIES**  
 Adult Faith Development Series at 9:30A  
 First Kids First, PreK-Grade 5 at 10:45A

**FREE MIDDAY ORGAN CONCERTS**  
 Thursdays at 12:10P, S. Wayne Foster, Organist

**THE 40<sup>TH</sup> ANNUAL ORGAN CONCERT SERIES**  
 SUNDAY, MAY 31 AT 4:00P  
 TODD WILSON, Organist  
 Order tickets online or 213.385.1345

**Dr. R. Scott Colglazier**  
 Senior Minister

**FIRST CONGREGATIONAL CHURCH of LOS ANGELES**  
 Wilshire Center . Commonwealth Ave at 6<sup>TH</sup> St. 213.385.1341 . [www.fccla.org](http://www.fccla.org)  
 The Largest Church Pipe Organ in the World

**Crime Wave from page 1**

wise down 7.5% from 2008 and 11.1% from 2007.

"Criminals are going to be criminals no matter what," said Davis. "They have made that decision and will continue their criminal activity regardless of [the] economy."

And if there is an increase in reported crime in the upcoming summer months, Davis said, it's typical. The LAPD receives more calls in the summer, he said, when schools are out and warmer nights breed opportunity for more drinking and parties.

**GGPNC from page 4**

But today, he said, he feels differently and is in favor of a 100% elected board because of the "appearance of impropriety."

"I say it's time for change," he said.

But others invoked the old adage: if it's not broken, why fix it?

"Why does this have to be changed," said Nora Mosqueda, a previous GGPNC board member. "I will get a petition that will do the opposite," if O'Grady's proposal is adopted, she said. "We should be doing more positive things for the community," than this.

Board members also weighed in on the matter. Nyla Arslanian, an appointed mem-

ber, said she had been invited to join the board, her resume extensively reviewed and then fully vetted by the board.

Laura Howe was elected to her position last year.

"I feel as if we are being put on the defensive, like we have done something wrong," she said. "The appointed members of this board have come [to work] time and time again. Democracy comes in many forms."

But Tor Hymans, a recently added appointed member, could only add: "There is something wrong here. How can I not respond to that," he said pointing to the hundreds of community signatures in protest. "I will never go against the wishes of so many."

Send the  
**Los Feliz Ledger**  
your letters or story ideas to:  
acohen@losfelizledger.com

Los Feliz Ledger's

# CLASSIFIED ADS

To place your classified ad, email us at [classified@losfelizledger.com](mailto:classified@losfelizledger.com)

HEALTH & MENTAL SERVICES	LEGAL SERVICES	ANNOUNCEMENTS
<p><b>NOW HEALING</b> Free Remote Healing Teleconferences 1st &amp; 3rd Saturdays, 9-10am. MAY 2 Heal Your Body: Aches, Pains, Injury, Allergies. MAY 16 Relationship Tune Up. <a href="http://www.nowhealing.com">www.nowhealing.com</a> / 323-309-7687</p>	<p><b>Los Feliz Attorney</b> provides 35 years experience in sale, lease and and finance real estate law. Contact Ron Weinstein, (323) 669-1875.</p>	<p><b>Join the Eastside Kids Club</b> Get discounts at your favorite neighborhood baby and kid stores! <a href="http://www.eastsidekidsclub.com">www.eastsidekidsclub.com</a> to find a store to register at today</p>
<p><b>PERSONAL SERVICES</b></p>	<p><b>Civil and Family Mediation</b> Work through relationship issues, even separation or divorce. Negotiate an agreement and/or divorce at a fraction of the cost. <a href="mailto:artfulmediation@gmail.com">artfulmediation@gmail.com</a> or phone (323) 300-5955.</p>	<p><b>CALL FOR ENTRIES</b> 3rd Annual Film Series at Cine Gear Expo in Hollywood Over \$100,000 in prize packages. To submit a film or buy screening tickets go to: <a href="http://www.cinegearexpo.com">www.cinegearexpo.com</a></p>
<p><b>Thoughtful Interfaith and Spiritual Minister/Officiant</b> for Weddings and Funerals Call (323) 497-2715</p>	<p><b>FOR SALE</b></p>	<p><b>SCHOOL BENEFIT</b> Rummage sale and family fun to benefit Hilltop Nursery School! Antiques, collectibles, records, more. Sun., 5/17. 7am to 2 pm. Citibank lot, corner Glendale/Silverlake Blvds.</p>
<p><b>NANNIES - HOUSEKEEPERS</b> We've served you for over 26 yrs with Honesty, Integrity &amp; Loyalty Licensed &amp; Bonded Jasmine Domestic Agency 323-937-0321 <a href="http://www.jasminedomesticagency.tk">www.jasminedomesticagency.tk</a></p>	<p><b>CAMERAS FOR SALE</b> Canon A1 35 mm SLR camera w/ 50 mm 1:1.8 canon lens w/ manual \$125.00. Canon lens FD 100mm 1:2.8 w/ hard case \$25.00. '70's Minolta Weathermatic-A 110 cartridge film under water camera w/ manual \$10.00 (323) 559-5016.</p>	<p><b>Silver Lake Art Craft &amp; Vintage</b> every Sat. from 10 a.m. - 4 p.m. Micheltorena St. Elementary School @ Micheltorena and Sunset Blvd., two blocks east of the Farmers' Market. (323) 953-0623, <a href="http://www.silverlakeartcraftvintage.com">www.silverlakeartcraftvintage.com</a></p>
<p><b>Procrastinating on your spring-cleaning?</b> heather brookes eco-friendly interior organization will get you started &amp; take you from clutter to clarity. Call us for a free consultation. 310.409.4690 <a href="http://www.heatherbrookes.org">www.heatherbrookes.org</a></p>	<p><b>Child's size German violin.</b> No bow. \$100. Collectible and antique dolls. (323) 662-2743</p>	
<p><b>JOBS OFFERED</b></p>	<p><b>Advertise in the Los Feliz Ledger Classified Section</b> \$30 for one Column Inch (Up to 30 words) To place your ad: <a href="mailto:classified@losfelizledger.com">classified@losfelizledger.com</a> Include Name, mailing address and contact information</p>	
<p><b>Silver Lake Beat Reporter</b> Needed for Los Feliz Ledger email: Allison Cohen at <a href="mailto:acohen@losfelizledger.com">acohen@losfelizledger.com</a></p>		



**IN ESCROW**

**210 S. WINDSOR BLVD. \$4,399,000**  
Gorgeous turnkey Mediterranean walking distance to Larchmont. Dramatic twin spiral staircase sweeps you up and away to Master "wing" w/fireplace, room size dressing room, bath spa and lanai w/downtown views! *Rescue dog sponsored with every home sale.*  
**SANDY ZALAGENS (310) 210-8742**



**5700 HOLLY OAK DRIVE \$2,949,000**  
Private, spectacular Modern retreat in Los Feliz Oaks. Jaw dropping views from almost every room. Seamless indoor/outdoor living includes dark bottom pool and spa w/ luxurious deck & flat grassy yards.  
**DOROTHY CARTER/MICHAEL ORLAND (323) 300-1025**

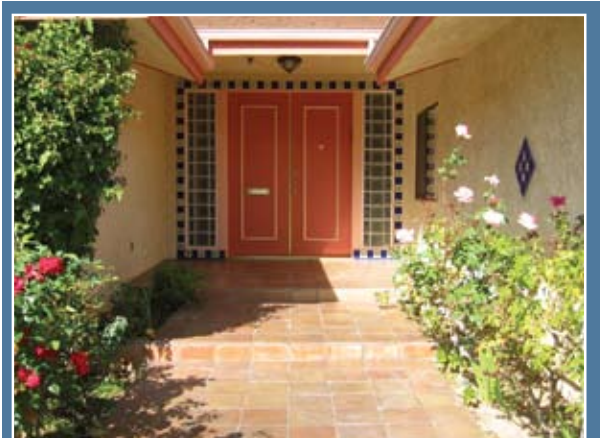

**2237 N. VERMONT AVE \$1,799,000**  
Lovely 5B, 4.5Ba + entertainment center. Frml LR/fireplace, Frml DR. Gourmet kitchen/granite counters, SS appliances. Maple floors in halls, LR&DR. Pool, spa, water fall. Grassy back yard w/ fruit trees. A/C Great Fam. /Entert.  
**MARTHA FREEMAN (310) 963-4006**  
**JOHN B. FREEMAN (310) 367-8178**



**3261 N. KNOLL DRIVE \$1,098,000**  
Exquisite home in the Hollywood Hills East. Totally rebuilt with modern luxuries. Approx. 2000sf, 7330 sf lot, 4 bd/3 ba. Wood plank & tile floors, wet bar, 2car garage. Views, 2 patios/balcony for entertaining. View by appt. only.  
**KAREN NUMME (323) 804-2008**

**KELLER WILLIAMS REALTY**

**We Are Moving to Hillhurst This Month!**

Please visit [www.KWHillhurst.com](http://www.KWHillhurst.com) for details!

**When Experience Counts!**

**Keller Williams Announces its Short Sale Division.**

**Headed by Steve Senigram + Champ Davenport**

**14 Years of Experience dealing with Lenders.**

**WE ARE MOVING TO A BIGGER SPACE!**  
[www.1660Hillhurst.com](http://www.1660Hillhurst.com)

**KELLER WILLIAMS REALTY**

Tel 323-300-1000 • Fax 323-300-1001  
[www.KWLosFeliz.com](http://www.KWLosFeliz.com)

**g&orge  
eileen  
moreno**  
REALTORS

2150 Hillhurst Avenue,  
Los Angeles, CA 90027  
**323.668.7600**  
georgeandeileen.com

RE/MAX

**Listed & Sold With  
Multiple Offers In  
Two Weeks!**



**8941 Wonderland Park Ave  
\$2,550,000**

Dear George & Eileen,

Thank you for the great work that you did selling our family home at 8941 Wonderland Park in Laurel Canyon. When our parents passed away recently & we decided to sell, we knew right away that you were the ones we wanted to handle the sale for us. You did such a great job listing and selling our home on Lyric Avenue in Los Feliz & representing us in the purchase of our current home in Silver Lake several years ago. We have continued to watch the impressive type of marketing you have done throughout the years since then and we knew we wanted you to be the ones to represent us again.

We want you to know that we were once again very happy with the work that you did this time as well. Selling a home for \$2,550,000 in December 2008 when our economy and real estate market were in such bad shape was a remarkable achievement - but selling it with multiple offers in 2 weeks was needless to say even more impressive. We will certainly continue to recommend you to anyone thinking of buying or selling in Los Feliz, Silver Lake, and the Hollywood Hills!

Best, David Zeiger and Maryann Nielsen



**Just Listed**



**2054 North New Hampshire Los Feliz \$799,000**  
Lovely 3 bed, 2 ba 1920's Spanish in Franklin Square w/beautifully landscaped front courtyard. Living rm opens thru an archway to a large formal DR. Charming kitchen opens to wonderful yard & patio w/arbor. A/C & copper pipes. Cozy family rm & hm office.

**Just Listed**



**2249 Duane Street Silver Lake \$835,000**  
Great investment or owner user property in Silver Lake. 4 large 1 bedrooms plus 2 bedroom & 1 bathroom owners unit with central air conditioning. Nice views from several units and large front yard. Walking distance to the reservoir, shops, & restaurants.

**For Sale**



**2700 Glendower Avenue Los Feliz Hills \$1,595,000**  
W.L. Skidmore Brick and Glass 3 bd 3 ba Masterpiece + full guest apt w/kitchen & full bath. Sweeping city views from downtown to the Westside & Griffith Park. Huge Gourmet kitchen, stunning LR opens to large view terrace. Cozy Media rm. 2 fireplaces.

**For Sale**



**71 Glen Summer Road Pasadena \$869,000**  
Beautifully renovated 3 bed & 2 bath Spanish home in the outstanding San Rafael neighborhood on one of the most beautiful tree lined streets in Pasadena. Gorgeous kitchen opens to family rm, old world character & details, hardwood floors, Cent A/C. Yard & deck.

**New Price**



**7250 Franklin Avenue #309 Hollywood Hills \$494,000**  
Spacious 2 bed & 2 bath condo w/views of Hollywood landmarks. Dining area, wet bar, nook for home office. Enjoy a gracious lifestyle living in this luxurious full service building, valet parking, concierge, pool, spa, fitness center w/roof top patio w/wraparound views.

**In Escrow**



**3600 Crestmont Ave Silver Lake \$1,275,000**  
A very special Four-Plex on a wonderful street to street lot & incredible views from downtown to the ocean. Fabulous 2 bd & 2 ba owners unit + 3 wonderful apartments each with fabulous views. Good income & 2 units will be delivered vacant at COE. Must See!

**In Escrow**



**3733 Clayton Avenue Los Feliz \$959,000**  
Stunning 4 Bd, 3 Ba Architectural w/views. Dramatic living room with fireplace opens to lovely patio. Large cook's kitchen w/large breakfast area. Formal dining room, polished concrete & honey colored hardwood flrs. Central A/C. Terraced patios & gardens.

**In Escrow**



**1971 Myra Avenue Los Feliz \$769,000**  
Charming 3 bd 1.5 ba Cape Cod set up high on a lovely knoll on a great corner location. Spacious living room with fireplace. Formal dining room, Newly refinished hardwood floors, A/C, copper plumbing. Great indoor outdoor flow. Franklin Elementary & Marshall High.

**In Escrow**



**1315 Romulus Drive Glendale Adams Hills \$519,000**  
Classic Adams Hill 2 bd 1 ba Spanish with home office & a pool! Spacious living room w/a fireplace & beamed ceiling steps down to sunny library area with view. Formal dining room. Walking distance to Adams Square. Great patio & swimming pool for summer parties!

**In Escrow**



**1945 Beachwood Drive Unit E Beachwood Canyon \$499,000**  
Fabulous spacious 3 bed & 2 1/2 ba townhouse in the desirable Beachwood Canyon area w/a wonderful floor plan that feels very much like a home. Remodeled kitchen, hardwood floors, formal dining room, fireplace, patio, good storage, laundry, 3 parking spaces.

**Sold**



**2237 Panorama Terrace Silver Lake Hills \$805,000**  
Character 4 Bed & 2 Ba Cape Cod home. Enter into a bright and sunny living room w/a fireplace that leads to wonderful deck w/picturesque views of the Silver Lake & Los Feliz hills. Formal dining room. Large street to street lot. Ivanhoe School District.